



SERVICE INFORMATION	17- 1
TROUBLESHOOTING	17- 2
BRAKE FLUID REPLACEMENT/ AIR BLEEDING	17- 3
BRAKE PAD/DISC	17- 5
FRONT MASTER CYLINDER	17- 8
FRONT BRAKE CALIPER	17-11
REAR MASTER CYLINDER	17-14
REAR BRAKE CALIPER	17-17
BRAKE PEDAL SHAFT	17-20

## SERVICE INFORMATION

### GENERAL INSTRUCTIONS

- The front and rear brakes can be removed without disconnecting the hydraulic system.
- Once the hydraulic systems have been opened, or if the brakes feel spongy, the system must be bled.
- Do not allow foreign material to enter the system when filling the reservoirs.
- Avoid spilling brake fluid on painted surfaces or instrument lenses, as severe damage will result.
- Always check brake operation before riding the motorcycle.

### TOOL

Special

Snap ring pliers

07914-3230001

### TORQUE VALUES

Brake hose bolt	2.5-3.5 kg-m (18-25 ft-lb)
Front brake caliper bracket	3.0-4.0 kg-m (22-29 ft-lb)
Front brake caliper	1.5-2.5 kg-m (11-18 ft-lb)
Rear brake caliper	1.5-2.5 kg-m (11-18 ft-lb)
Rear master cylinder	3.0-4.0 kg-m (22-29 ft-lb)
Rear brake torque rod nut	1.8-2.5 kg-m (13-18 ft-lb)
Rear axle nut	8.0-10.0 kg-m (58-72 ft-lb)

### SPECIFICATIONS

	STANDARD	SERVICE LIMIT
Front disc thickness	4.8-5.2 mm (0.19-0.20 in)	4.0 mm (0.16 in)
Front disc runout	—	0.30 mm (0.012 in)
Front master cylinder I.D.	15.870-15.913 mm (0.6248-0.6265 in)	15.925 mm (0.6270 in)
Front master piston O.D.	15.827-15.854 mm (0.6231-0.6242 in)	15.815 mm (0.6226 in)
Front caliper piston O.D.	38.098-38.148 mm (1.4999-1.5019 in)	38.09 mm (1.500 in)
Front caliper cylinder I.D.	38.180-38.230 mm (1.5031-1.5051 in)	38.24 mm (1.506 in)
Rear master cylinder I.D.	14.000-14.043 mm (0.5512-0.5529 in)	14.06 mm (0.553 in)
Rear master piston O.D.	13.957-13.984 mm (0.5495-0.5506 in)	13.95 mm (0.549 in)
Rear caliper cylinder I.D.	42.85-42.90 mm (1.687-1.689 in)	42.9 mm (1.69 in)
Rear caliper piston O.D.	42.772-42.822 mm (1.6939-1.6859 in)	42.76 mm (1.684 in)
Rear disc thickness	6.8-7.2 mm (0.27-0.28 in)	6.0 mm (0.24 in)
Rear disc runout	—	0.30 mm (0.012 in)



## **TROUBLESHOOTING**

### **Brake Lever/Pedal Soft or Spongy**

1. Air bubbles in hydraulic system
2. Low fluid level
3. Hydraulic system leaking

### **Brake Lever/Pedal Too Hard**

1. Sticking piston(s)
2. Clogged hydraulic system
3. Pads glazed or worn excessively

### **Brakes Drag**

1. Hydraulic system sticking
2. Incorrect adjustment of lever or pedal
3. Sticking piston(s)

### **Brakes Grab or Pull to One Side**

1. Pads contaminated
2. One side front brake faulty
3. Disc or wheel misaligned

### **Brakes Chatter or Squeal**

1. Pads contaminated
2. Excessive disc runout
3. Caliper installed incorrectly
4. Disc or wheel misaligned



## **BRAKE FLUID REPLACEMENT/ AIR BLEEDING**

Check the fluid level with the fluid reservoir parallel to the ground.

### **CAUTION:**

- *Install the diaphragm on the reservoir when operating the brake lever/pedal. Failure to do so will allow brake fluid to squirt out of the reservoir during brake operation.*
- *Avoid spilling fluid on painted surfaces. Place a rag over the fuel tank whenever the system is serviced.*

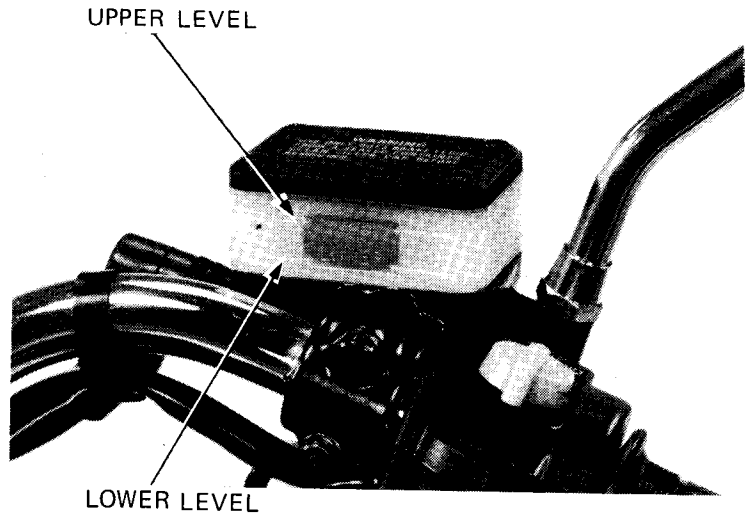

## **BRAKE FLUID DRAINING**

Connect a bleed hose to the bleeder valve.  
Loosen the caliper bleeder valve and pump the brake lever (or pedal).  
Stop operating the lever (or pedal) when no fluid flows out of the bleeder valve.

### **WARNING**

*A contaminated brake disc or pad reduces stopping power. Discard contaminated pads and clean a contaminated disc with a high quality brake degreasing agent.*

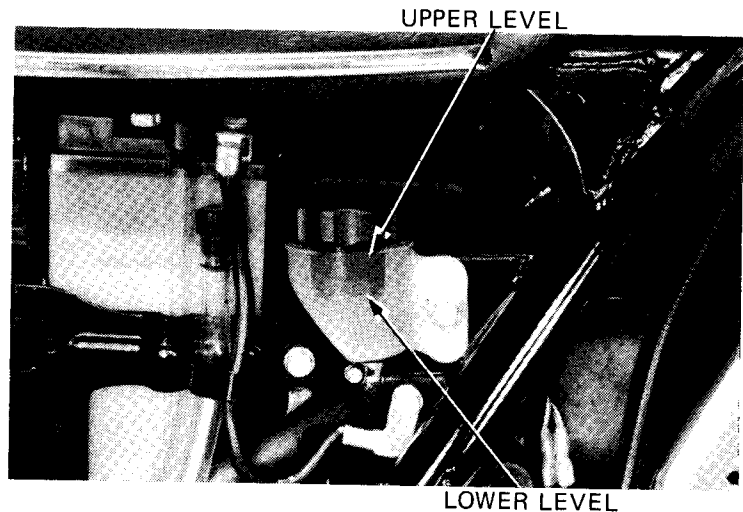

## **BRAKE FLUID FILLING**

### **NOTE**

**Do not mix different types of fluid since they may not be compatible.**

Close the bleeder valve, fill the reservoir, and install the diaphragm.

To prevent piston overtravel and brake fluid seepage, keep a 20 mm (3/4 in) space to the handlebar grip when bleeding the front brake system. Pump up the system pressure with the lever until there are no air bubbles in the fluid flowing out of the reservoir small hole and lever (or pedal) resistance is felt.



## AIR BLEEDING

### NOTE

- Use this procedure for the front and rear brakes.
- Check the fluid level often while bleeding the brake to prevent air from being pumped into the system.
- Use only **SAE J1703** or **DOT 3** brake fluid from a sealed container.
- Do not mix brake fluid types and never re-use the contaminated fluid which has been pumped out during brake bleeding, because this will impair the efficiency of the brake system.

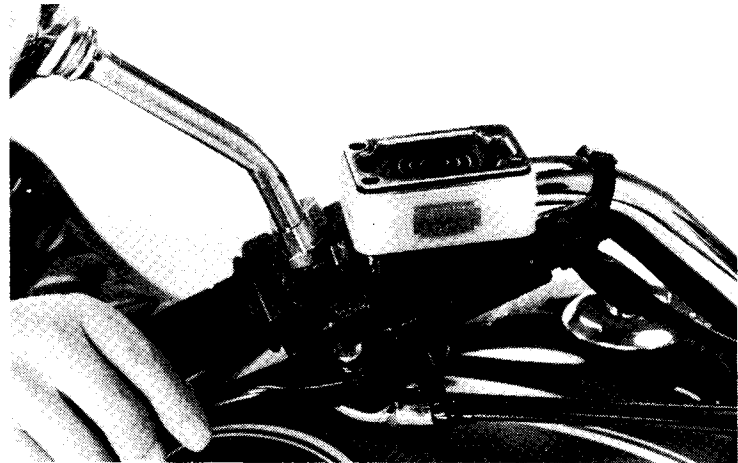

- i) Squeeze the brake lever (or depress the brake pedal), open the bleeder valve 1/2 turn then close the valve.

### NOTE

Do not release the brake lever (or pedal) until the bleeder valve has been closed again.

- ii) Release the brake lever (or pedal) slowly and wait several seconds after it reaches the end of its travel.

Repeat the above steps i) and ii) until bubbles cease to appear in the fluid at the end of the hose.

Fill the fluid reservoir to the upper level mark.

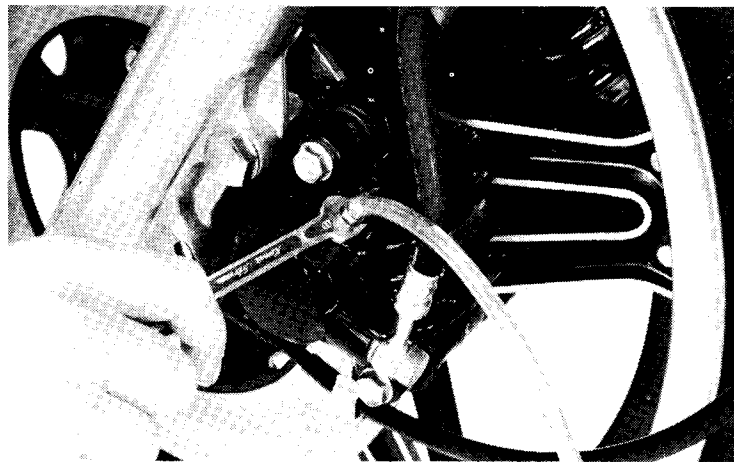

### **WARNING**

*A contaminated brake disc or pad reduces stopping power. Discard contaminated pads and clean a contaminated disc with a high quality brake degreasing agent.*

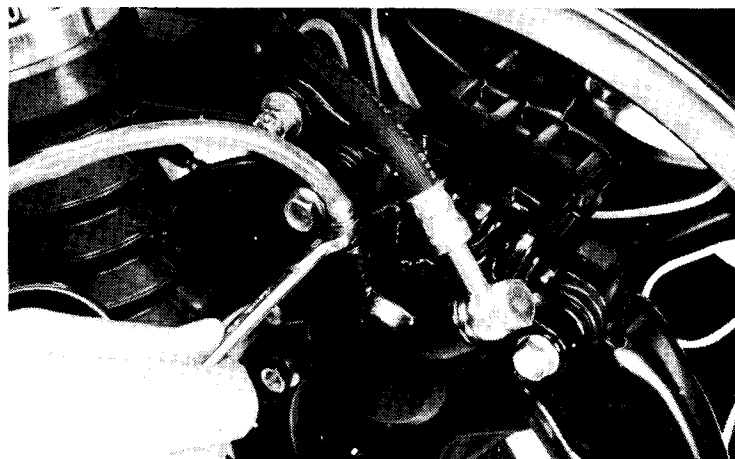



## BRAKE PAD/DISC

### FRONT PAD REPLACEMENT

Replace the front brake pads if the red line on the top of the pads reaches the edge of the brake disc.

#### NOTE

Always replace the brake pads in pairs to assure even disc pressure.

Remove the two caliper bolts.

Lift off the caliper and remove both brake pads and the shim.

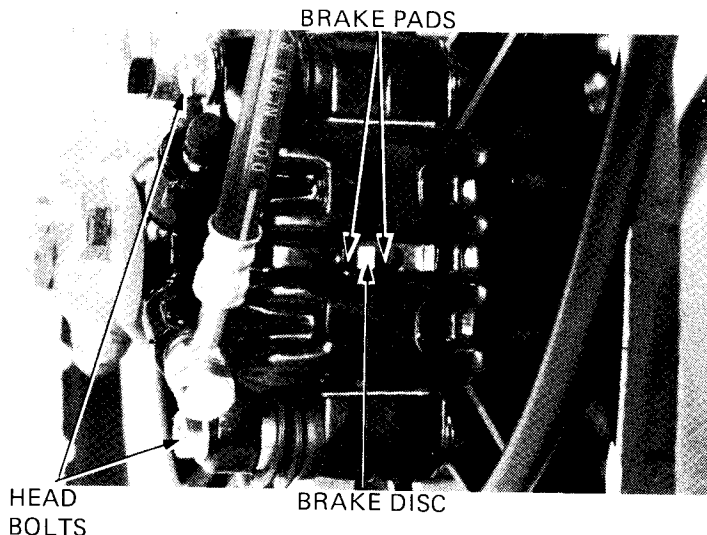

Install the new brake pads and the shim.

#### NOTE

Install the shims with the mark "↑" facing up.

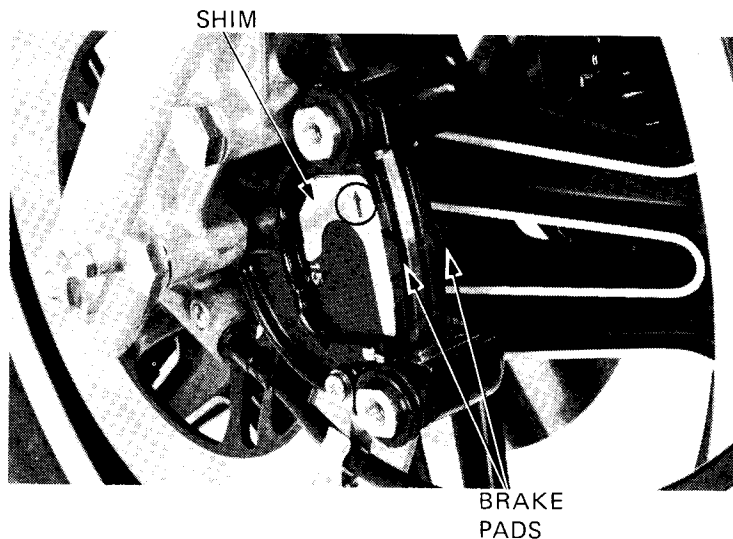

Inspect the piston boot for damage or deterioration.

Push the brake caliper cylinder in all the way.

#### NOTE

Check the brake fluid level in the reservoir as this causes the level to rise.

Insert the caliper pin into the caliper bracket with the chamfered end facing as shown.

Inspect the dust cover condition.

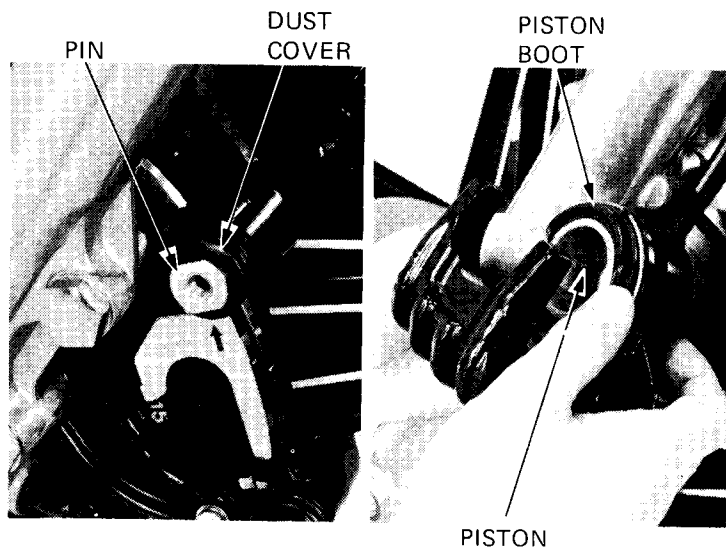



Install the brake caliper with the two bolts.

**TORQUE:** 1.5–2.5 kg-m, (11–18 ft-lb)

**NOTE**

Tighten the bolts evenly in 2-3 steps.

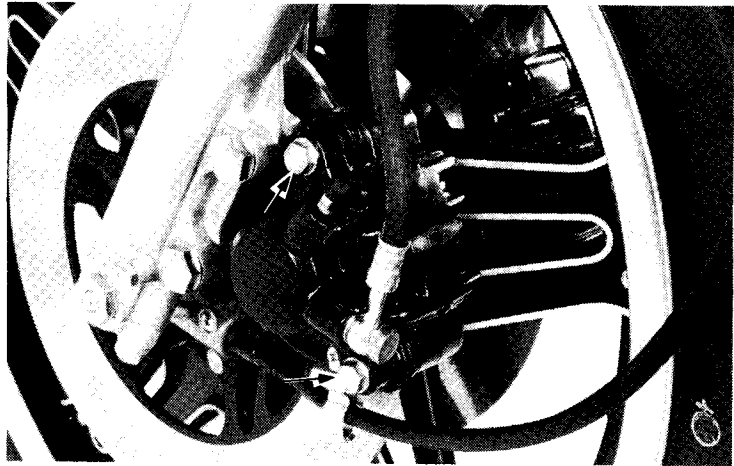

### REAR BRAKE PAD REPLACEMENT

Replace the rear brake pads if the red line on the top of the pads reaches the edge of the brake disc.

**NOTE**

Always replace both pads to assure even disc pressure.

Remove the two caliper bolts.  
Lift the caliper off and remove both brake pads and shim.

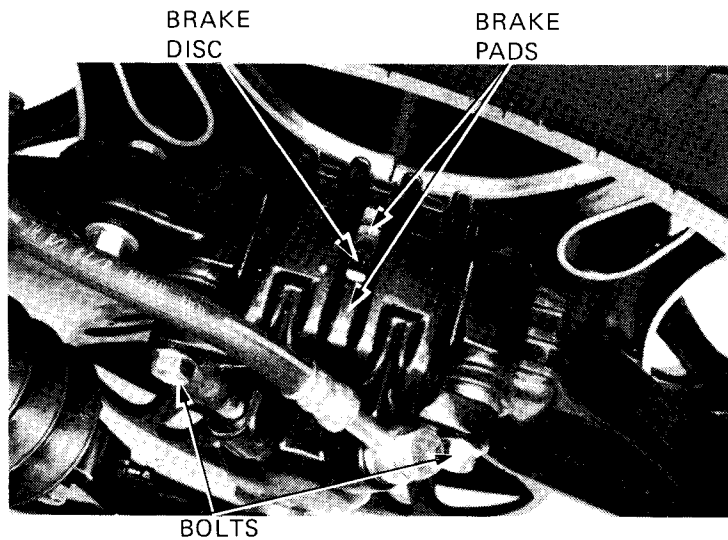

Install new pads and the shims.

**NOTE**

- Always replace the brake pads in pairs to assure even disc pressure.
- Install the shim on the piston side with the "↑" in the direction of normal wheel rotation.

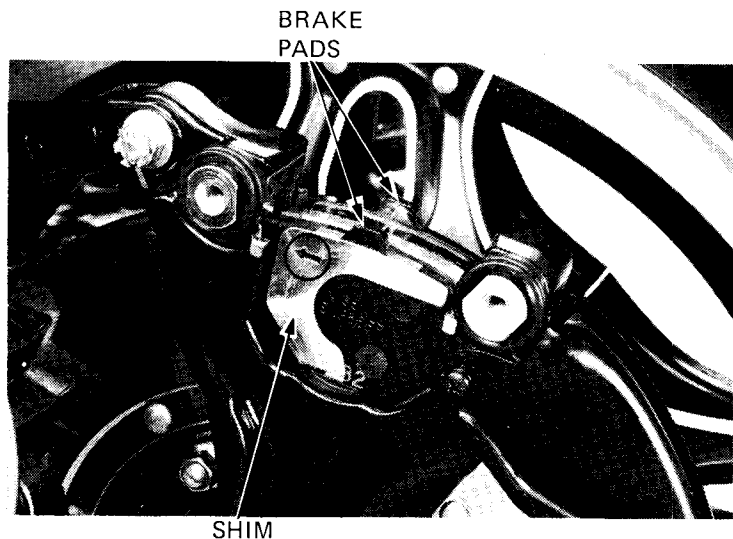



Press the piston back into the caliper. Check the brake fluid level in the brake master cylinder reservoir as this causes the level to rise.

Inspect the piston boot for damage or deterioration.

Insert the pin through the caliper bracket with the chamfered end facing as shown.

Inspect the condition of the dust covers.

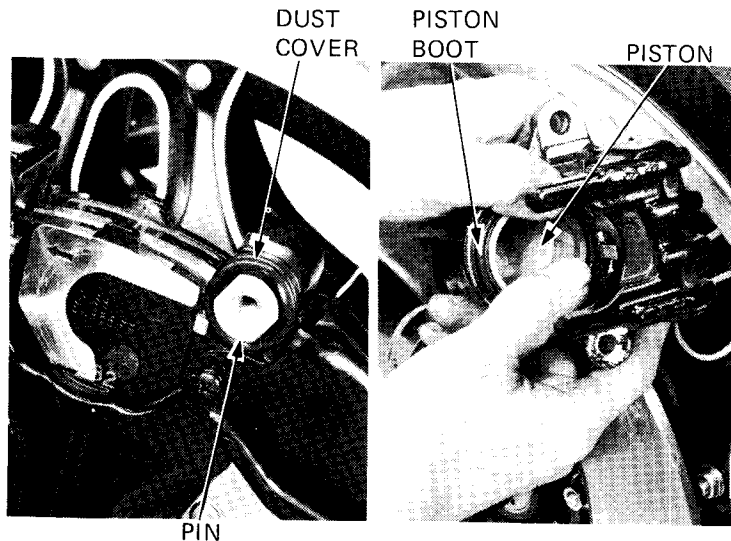

Install the brake caliper with the two bolts.

### NOTE

Tighten the bolts evenly in 2-3 steps.

**TORQUE: 1.5–2.5 kg-m, (11–18 ft-lb)**

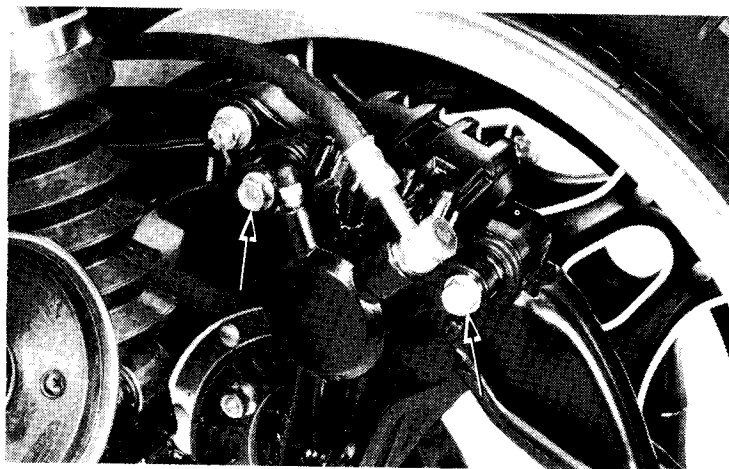

### DISC THICKNESS

Measure the disc thickness.

### SERVICE LIMIT:

**FRONT: 4.0 mm (0.16 in)**

**REAR: 6.0 mm (0.24 in)**

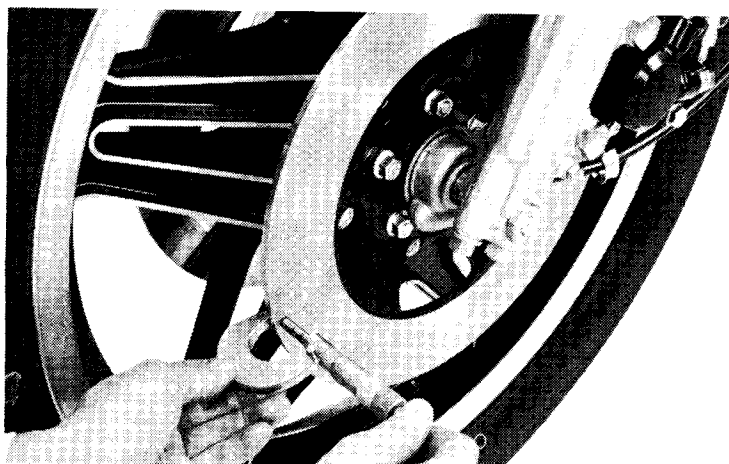





### BRAKE DISC WARPAGE

Measure brake disc warpage.

**SERVICE LIMIT: 0.3 mm (0.012 in)**

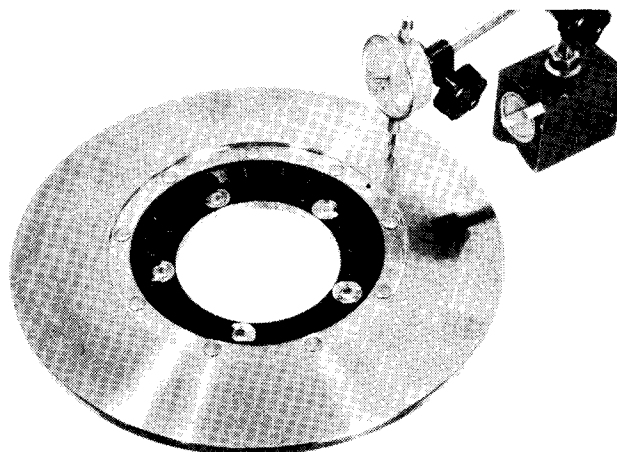

### FRONT MASTER CYLINDER

#### DISASSEMBLY

Drain brake fluid from the hydraulic system. Remove the brake lever and rear view mirror from the master cylinder. Disconnect the brake hose.

#### CAUTION:

*Avoid spilling brake fluid on painted surfaces.  
Place a rag over the fuel tank whenever the brake system is serviced.*

#### NOTE

*When removing the oil bolt, cover the end of the hose to prevent contamination and secure the hose.*

Remove the master cylinder.

Remove the boot.  
Remove the circlip from the master cylinder body.

BRAKE HOSE

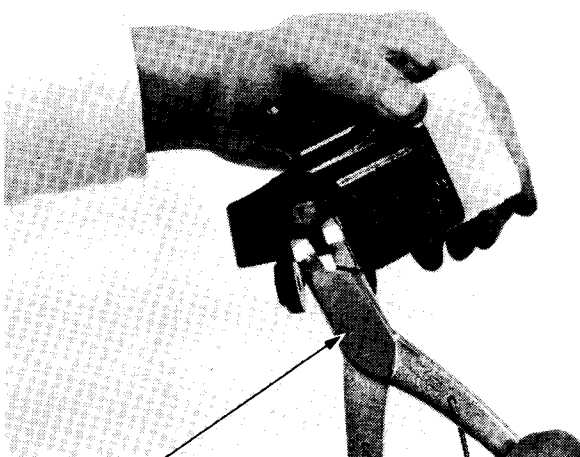
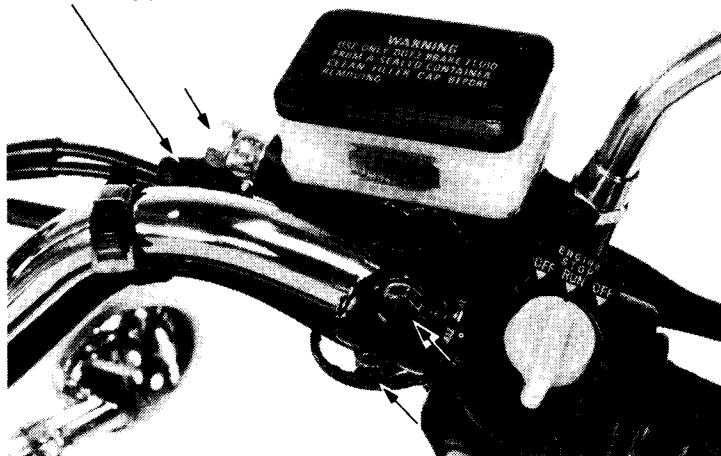

SNAP RING PLIERS  
07914-323001



Remove the stop plate, secondary cup and master piston.

Then remove the primary cup and spring.

Remove the brake fluid reservoir from the master cylinder body, if necessary.

Clean the inside of the master cylinder and reservoir with brake fluid.

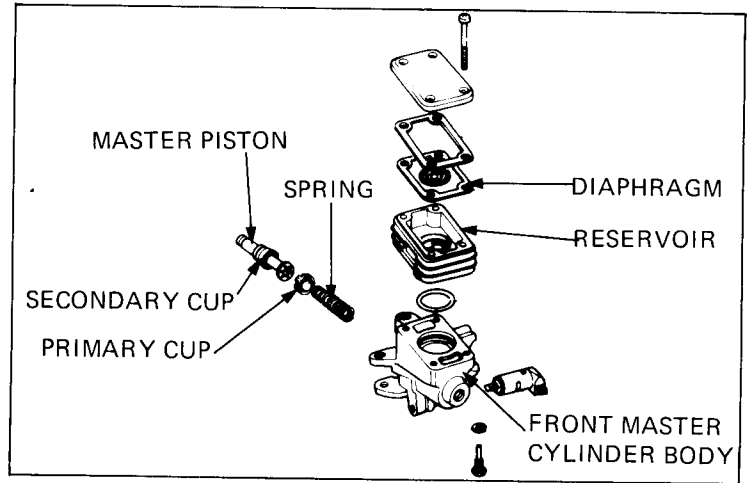

### FRONT MASTER CYLINDER I.D. INSPECTION

Measure the master cylinder I.D.

Check the master cylinder for scores, scratches or nicks.

**SERVICE LIMIT: 15.925 mm (0.6270 in)**

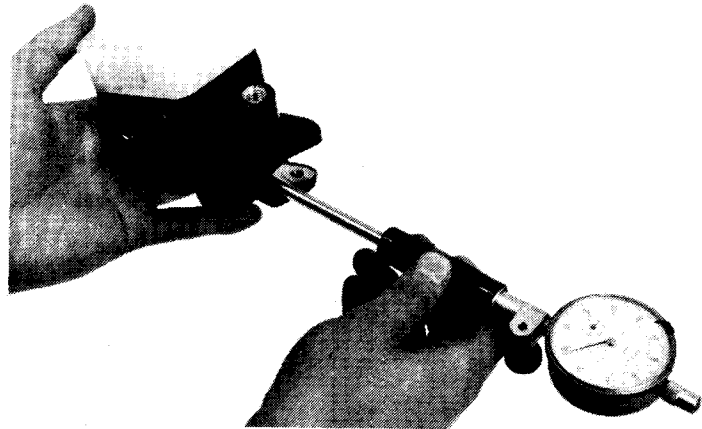

### FRONT MASTER PISTON O.D. INSPECTION

Measure the master piston O.D.

**SERVICE LIMIT: 15.815 mm (0.6226 in)**

Check the primary cup and secondary cup for damage before assembly.

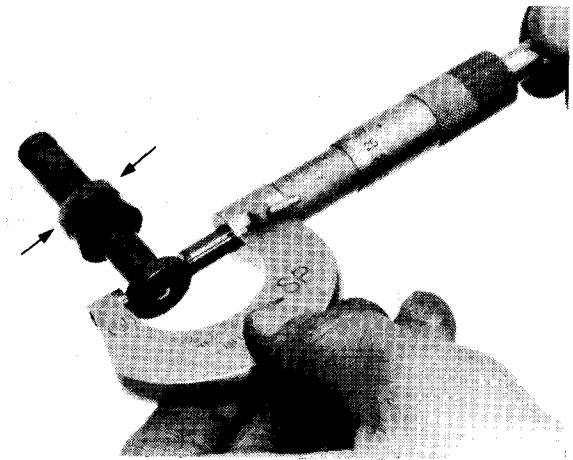



**ASSEMBLY**

**CAUTION:**

*Handle the master cylinder piston, cylinder and spring as a set.*

Assemble the master cylinder. Coat all parts with clean brake fluid before assembly. Install the spring and valve together.

Dip the piston cup in brake fluid before assembly.

**CAUTION:**

*When installing the cups, do not allow the lips to turn inside out. Be certain the circlip is seated firmly in the groove.*

Install the boot, washer and clip. Install the reservoir on the master cylinder making sure that the O-ring is in good condition.

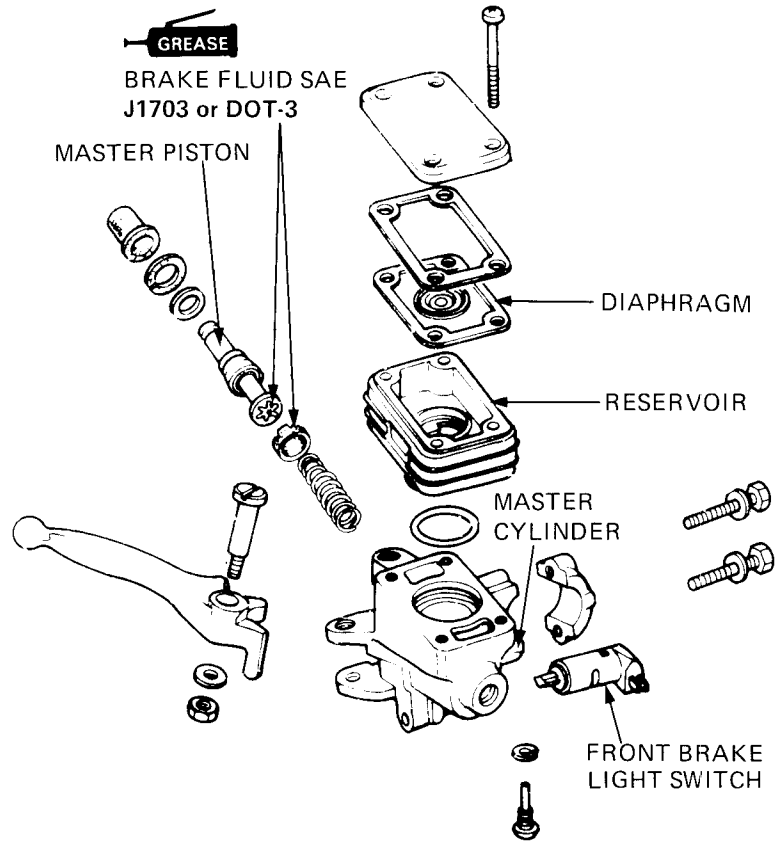

Place the master cylinder on the handlebar and install the holder and the two mounting bolts. Tighten the top bolt first. Install the oil hose with the bolt and its two sealing washers. Install the brake lever.

Before installing the lever nut, install the rubber tube from the bottom side of the cylinder, the plate, and nut.

Fill the reservoir to the upper level and bleed the brake system according to page 17-4.

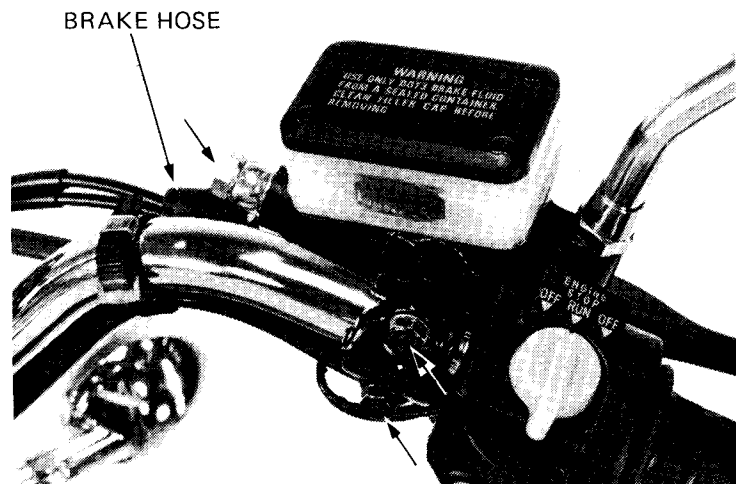



## FRONT BRAKE CALIPER

### DISASSEMBLY

Place a clean container under the caliper and disconnect the brake hose bolt.

#### NOTE

Avoid spilling brake fluid on painted surfaces.

Remove the caliper.

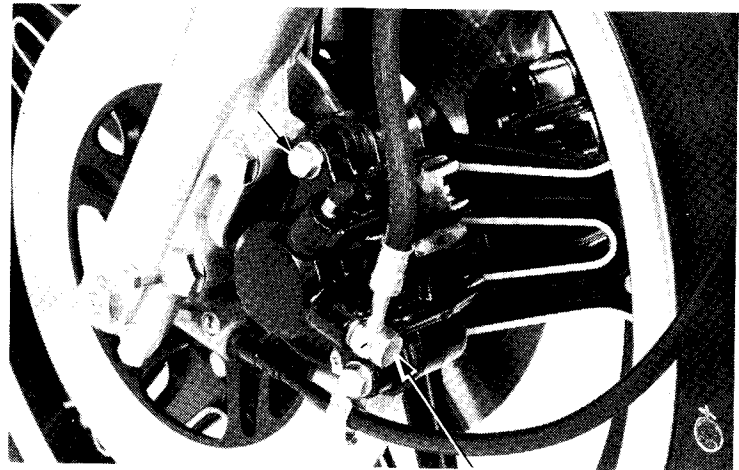

OIL BOLT

Observe the position of the pad spring.  
Remove the piston boot and boot clip.

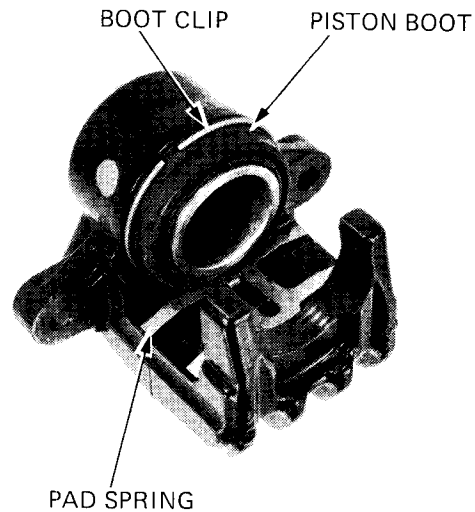

Place a shop towel over the piston to prevent the piston from coming out, and position the caliper with the piston down.  
Apply a small amount of air pressure to the fluid inlet.

#### **WARNING**

*Do not use high pressure air or bring the nozzle too close to the inlet.*

Examine the piston and cylinder for scoring or scratches and replace if necessary.

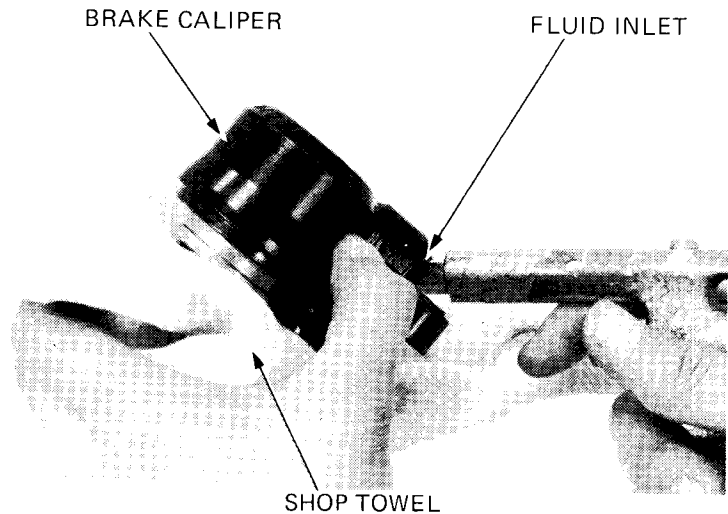

SHOP TOWEL



256 HYDRAULIC BRAKE

Remove the oil seal by first pushing it into the cylinder as shown.  
Clean the caliper grooves with brake fluid.

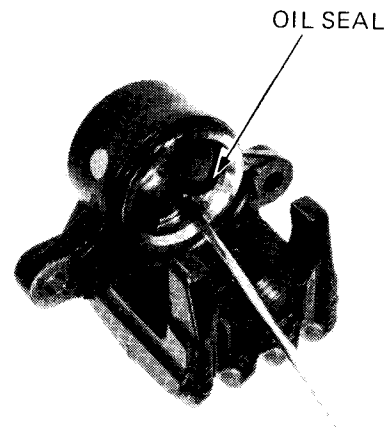

**FRONT CALIPER PISTON O.D. INSPECTION**

Check the piston for scoring or scratches. Measure the outside diameter of the piston with a micrometer.

**SERVICE LIMIT: 38.09 mm (1.500 in)**

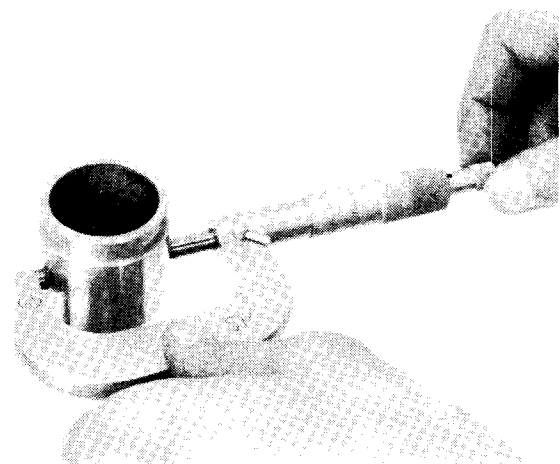

**FRONT CALIPER CYLINDER I.D. INSPECTION**

Check the caliper cylinder for scoring or scratches. Measure the inside diameter of the caliper cylinder bore.

**SERVICE LIMIT: 38.24 mm (1.506 in)**

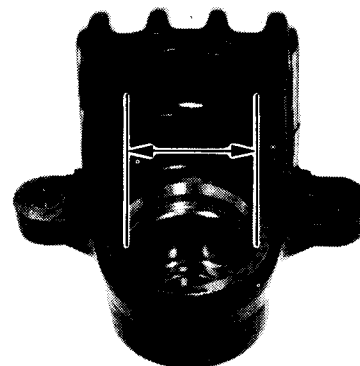



### ASSEMBLY

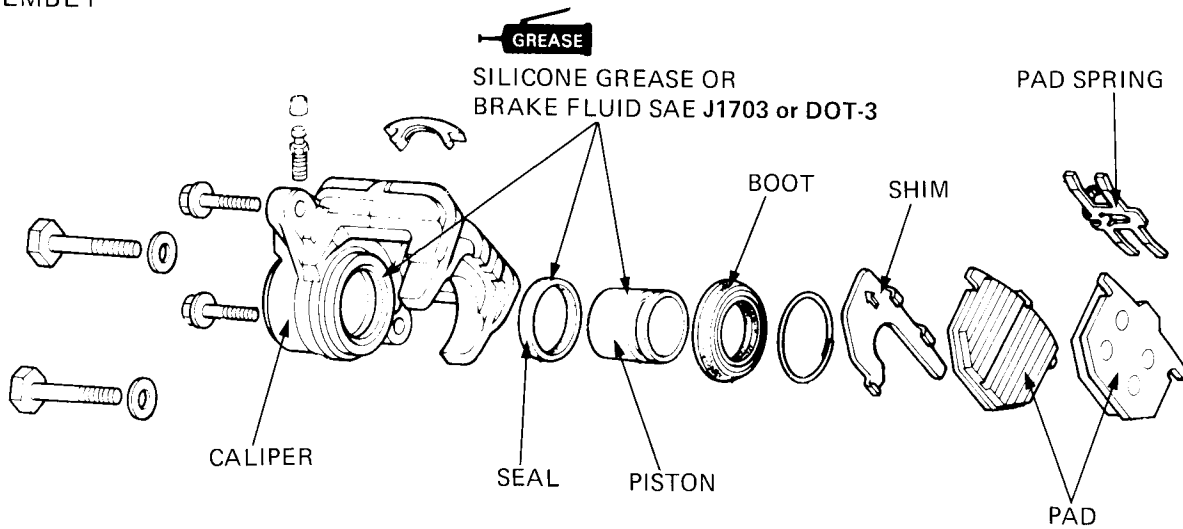

#### **WARNING**

*A contaminated brake disc or pad reduces stopping power. Do not allow grease on the brake pads.*

Assemble the caliper in the reverse order of disassembly. The oil seal must be replaced with a new one whenever removed. Lubricate the piston and seal with a medium grade of Hi-Temperature silicone grease or brake fluid before assembly.

Be certain the piston seal is seated in the caliper groove.

Place the piston in the caliper with the boot lip facing out. Install the boot and clip on the piston.

Install the front brake caliper assembly (page 15-5).

Install the caliper holding bolts. Install the oil bolt and the two sealing washers.

Fill the brake fluid reservoir and bleed the front brake system (page 17-4).

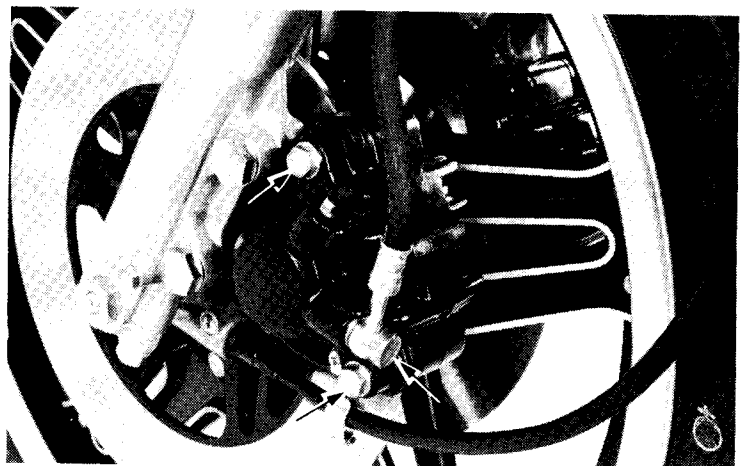



258 **HYDRAULIC BRAKE**

**FRONT CALIPER BRACKET  
DISASSEMBLY**

Remove the speedometer cable clamp.

Remove the two caliper bracket attaching bolts and remove the caliper bracket.

Remove the pins and dust covers from the caliper bracket, making sure that they are in good condition.

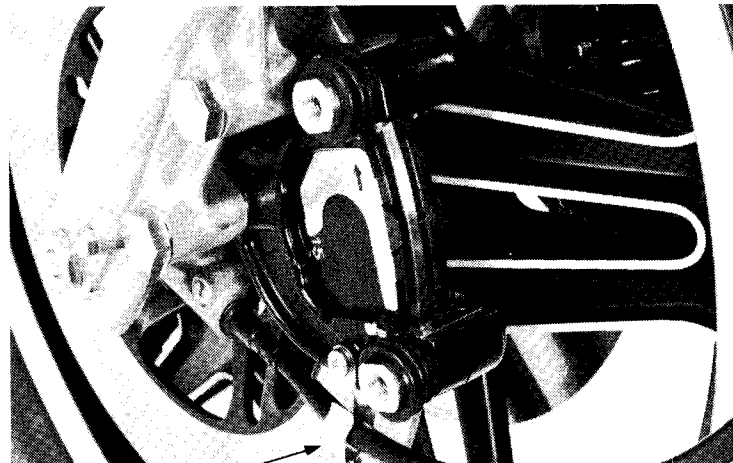

CABLE CLAMP

**FRONT CALIPER BRACKET  
ASSEMBLY**

Wash all removed parts with brake fluid. Make sure that both pins move freely in and out of the caliper pin holes.

Lubricate both pins with a medium grade Hi-Temperature silicone grease before assembly.

Attach the caliper bracket to the front fork.

**TORQUE: 3.0-4.0 kg (22-29 ft-lb)**

Install the front caliper (page 17-5).

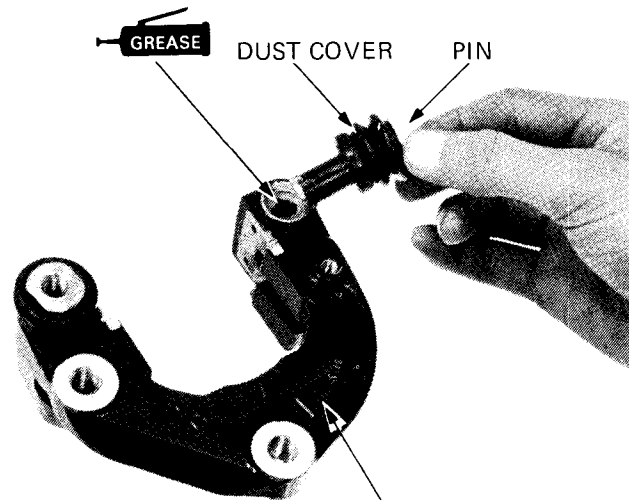

FRONT CALIPER  
BRACKET

**REAR MASTER CYLINDER**

**REMOVAL**

Remove the right side cover.

Remove the brake pedal.

Remove the master cylinder setting bolts.

Remove the brake pedal bracket.

Remove the cotter pin and joint pin.

BRAKE PEDAL BRACKET

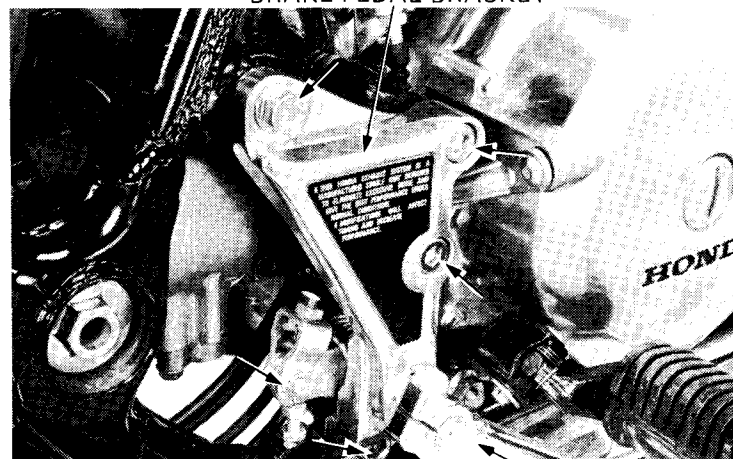

BRAKE PEDAL



Place a clean drip pan under the brake line. Disconnect the brake line on the back of the master cylinder.

**CAUTION:**

*Avoid spilling brake fluid on painted surfaces.*

MASTER CYLINDER

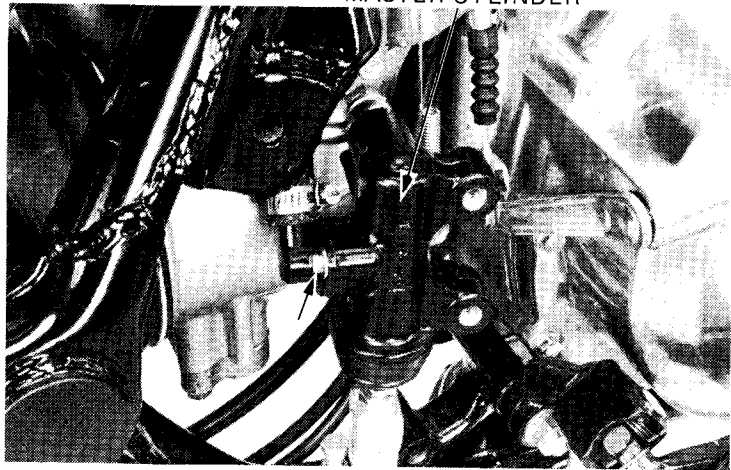

**DISASSEMBLY**

Remove the rubber cover.  
Remove the circlip and push rod from the master cylinder body.

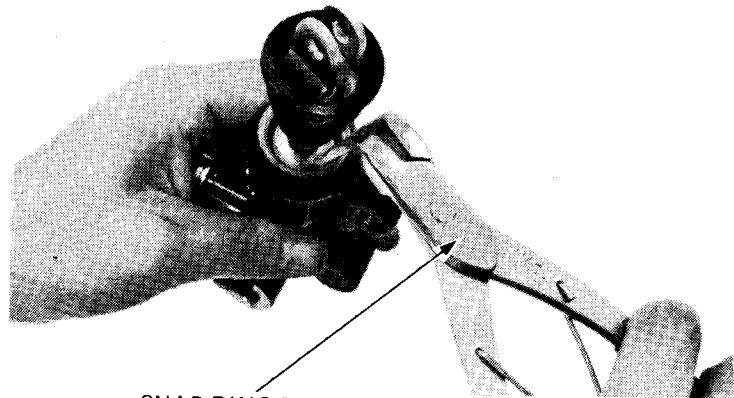

SNAP RING PLIERS  
07914-3230001

Remove the master piston, primary cup and spring.

It may be necessary to apply a small amount of air pressure to the fluid outlet to remove the master piston and primary cup.

Clean all parts with brake fluid.

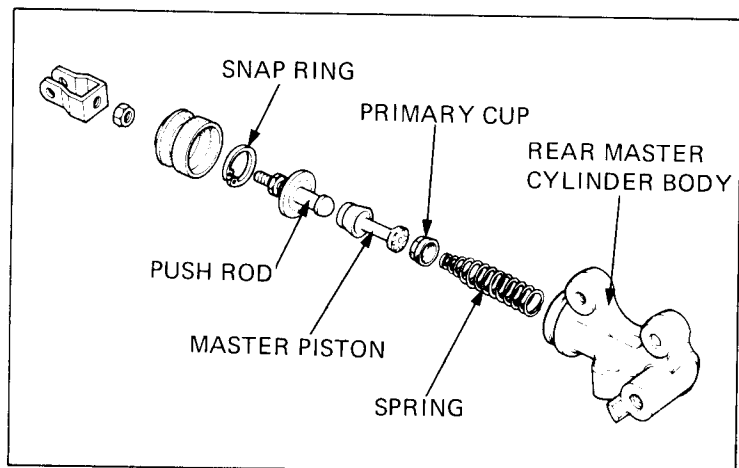





260 HYDRAULIC BRAKE

**REAR MASTER CYLINDER I.D. INSPECTION**

Measure the inside diameter of the master cylinder bore.

**SERVICE LIMIT: 14.06 mm (0.553 in)**

Check for scores, scratches or nicks.

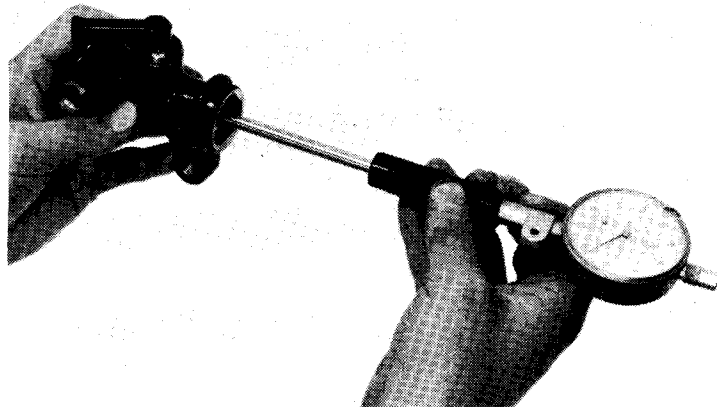

**REAR MASTER PISTON O.D. INSPECTION**

Measure the master piston O.D.

**SERVICE LIMIT: 13.95 mm (0.549 in)**

Check the primary cup and secondary cup for damage before assembly.

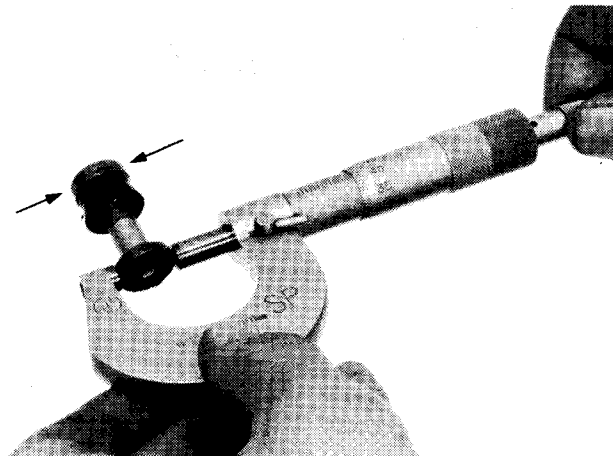

**REAR MASTER CYLINDER ASSEMBLY**

**CAUTION:**

*Handle the master cylinder piston, cylinder and spring as a set.*

Assemble the master cylinder.  
Coat all parts with clean brake fluid.

Dip the piston cup in brake fluid before assembly.

**CAUTION:**

*When installing the cups, do not allow the lips to turn inside out. Be certain the snap ring is seated firmly in the groove.*

Install the primary cup and piston.  
Install the push rod and circlip.  
Install the boot, nut and rod eye.

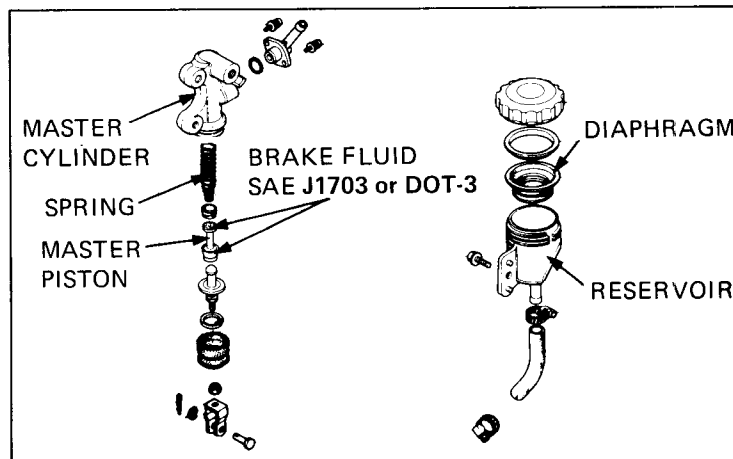



Install the master cylinder on the master cylinder bracket.

**TORQUE:** 3.0–4.0 kg-m (22–29 ft-lb)

Connect the brake hose and brake rod.

Bleed the brake hydraulic system after assembly. (page 17-4)

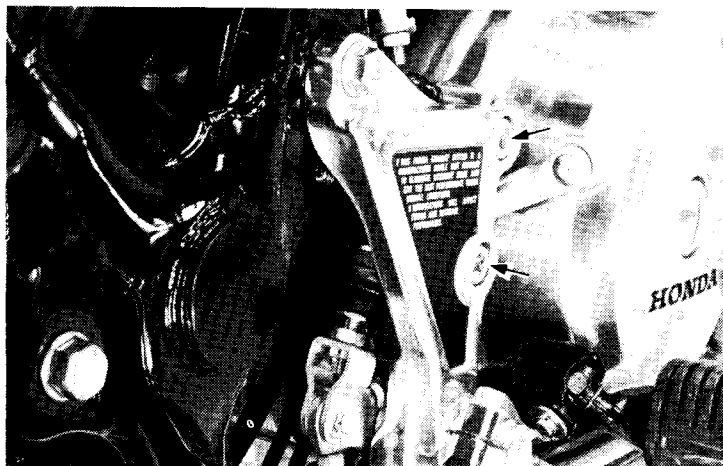

## REAR BRAKE CALIPER

### REMOVAL

Drain the brake hydraulic system.  
Disconnect the brake hose.

### NOTE

Avoid spilling brake fluid on painted surfaces and the brake surfaces.

Remove the two brake caliper bolts and caliper.

### DISASSEMBLY

Refer to Front Brake Caliper. (Page 17-11)

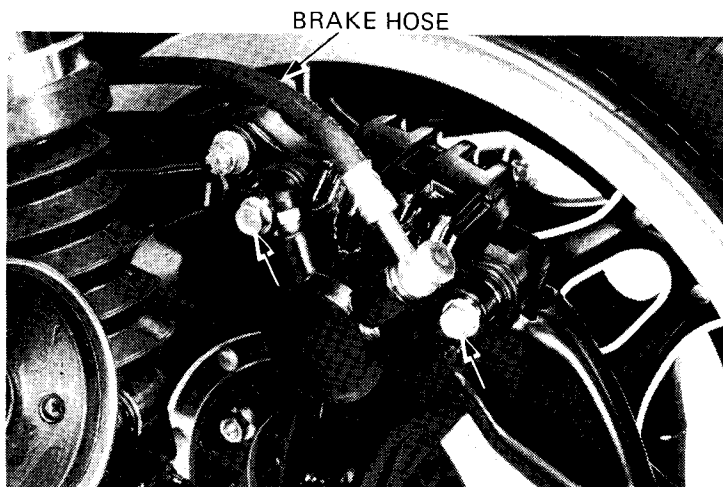

## REAR BRAKE CALIPER PISTON O.D. INSPECTION

Check the piston for scoring or scratches.  
Measure the piston diameter.

**SERVICE LIMIT:** 42.76 mm (1.684 in)

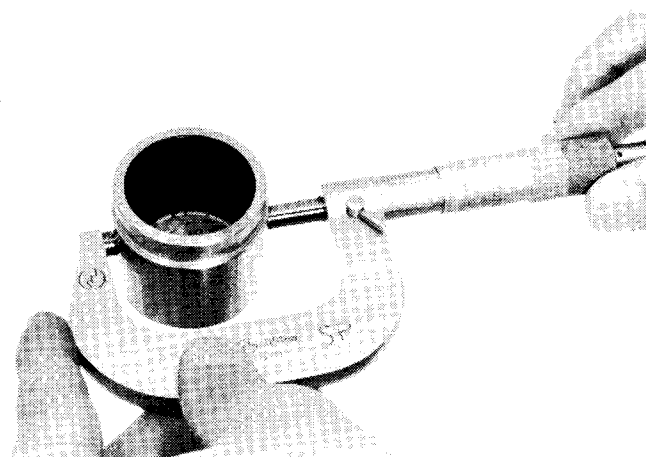



262 HYDRAULIC BRAKE

**REAR BRAKE CALIPER CYLINDER  
I.D. INSPECTION**

Check the caliper cylinder for scoring or scratches.

Measure the inside diameter of the caliper cylinder bore.

**SERVICE LIMIT: 42.9 mm (1.69 in)**

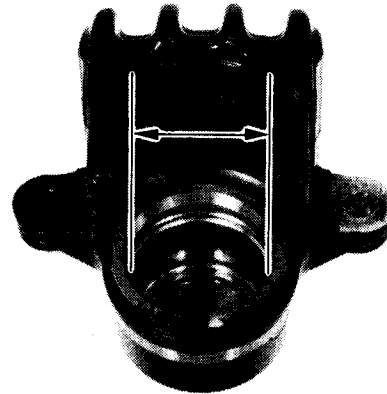

**ASSEMBLY**

Refer to the Front Brake Caliper (page 17-13).

**WARNING**

*A contaminated brake disc or pad reduces stopping power. Do not allow grease to contact pad faces.*

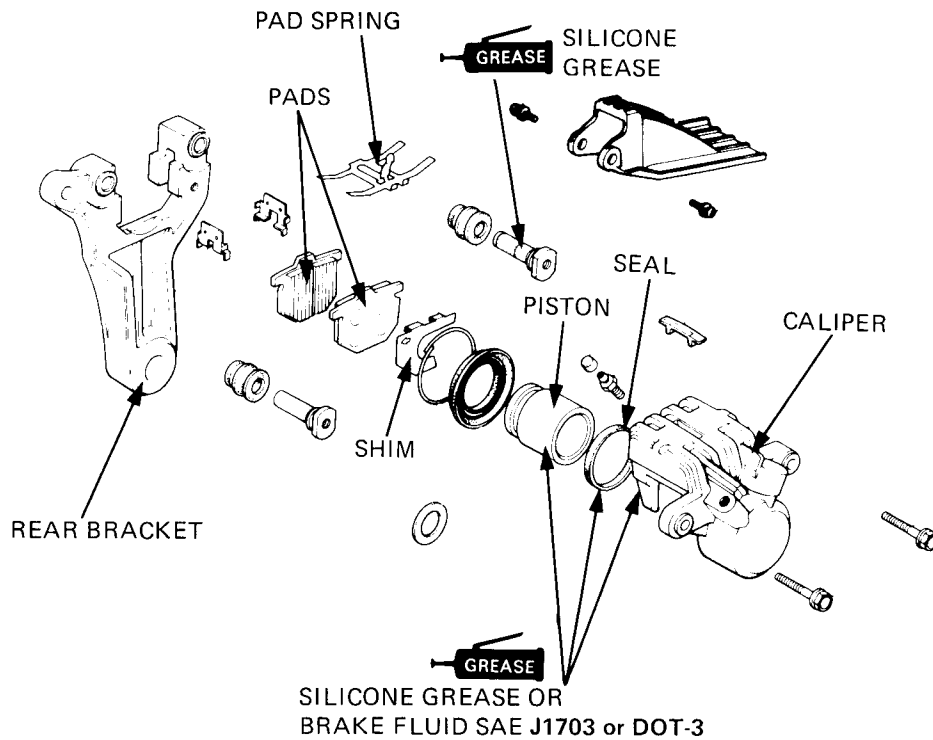



### REAR CALIPER BRACKET DISASSEMBLY

Remove the rear brake caliper (page 17-17).  
Remove the axle nut and rear axle (page 15-2).  
Remove the cotter pin and nut.  
Disconnect the brake torque link from the rear brake caliper bracket.  
Remove the rear caliper bracket.  
Remove the pins and dust cover and check for damage.

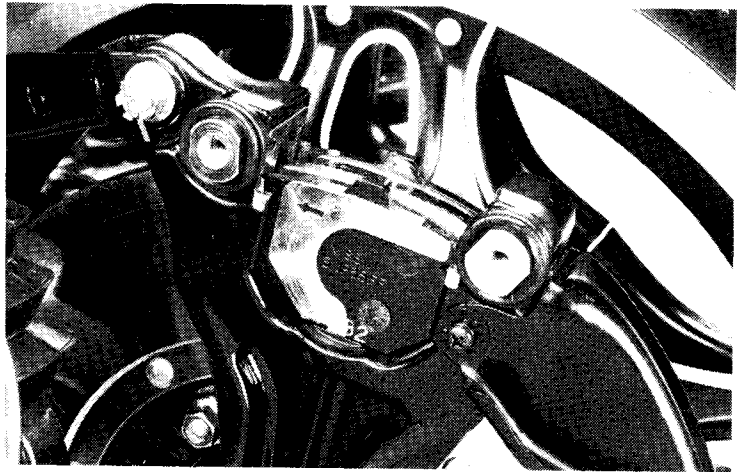

### REAR CALIPER BRACKET ASSEMBLY

Make sure that both pins move freely in and out of the caliper pin holes.  
Lubricate both pins with a medium grade Hi-Temperature Silicone grease before assembly.

Install the rear caliper bracket in the reverse order of removal.

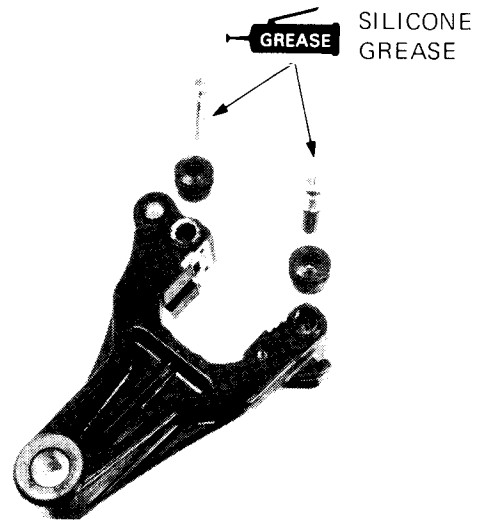



## BRAKE PEDAL SHAFT

### REMOVAL/INSTALLATION

#### NOTE

The brake pedal shaft can be removed and installed without removing the muffler.

Remove the brake pedal.

Remove the allen head bolt and rod pin.  
Remove the rear master cylinder.

Remove the rear brakelight switch spring and rear brake pedal shaft.

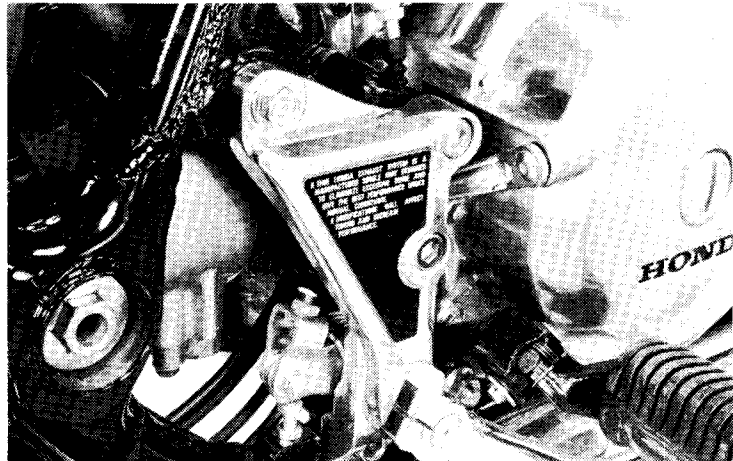

Install the brake return spring as shown.

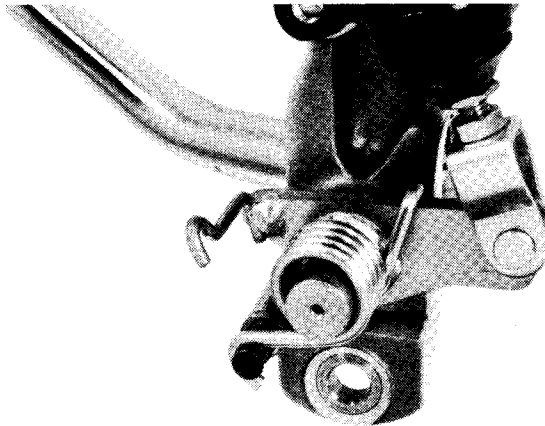

Align the punch marks and install the rear brake pedal.

PUNCH MARKS

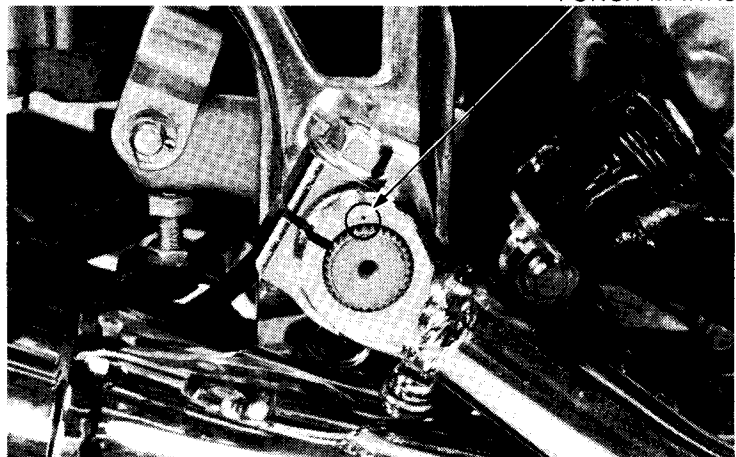



MEMO