



SERVICE INFORMATION	13- 1
TROUBLESHOOTING	13- 2
PRIMARY SHAFT REMOVAL	13- 3
PRIMARY SHAFT DISASSEMBLY	13- 3
PRIMARY CHAIN TENSIONER DISASSEMBLY	13- 4
CONNECTING ROD REMOVAL	13- 4
BEARING INSPECTION	13- 6
BEARING SELECTION	13- 8
CONNECTING ROD INSTALLATION	13-10
PRIMARY SHAFT ASSEMBLY	13-12
PRIMARY CHAIN TENSIONER ASSEMBLY	13-13

## SERVICE INFORMATION

### GENERAL INSTRUCTIONS

- All bearing inserts are select fit and are identified by color code. Select replacement bearings from the code tables. After installing new bearings, recheck them with plastigauge to verify clearance.
- Apply molybdenum disulfide grease to the main journals and crankpins during assembly.

### TOOLS

#### Common

Driver Handle	07746-0020100
20 mm Inner driver	07746-0030200

### TORQUE VALUES

Crankpin	3.2 kg-m (23 ft-lb)
Crankshaft	2.1-2.5 kg-m (15-18 ft-lb)
Primary chain tensioner bolt	0.8-1.2 kg-m ( 6- 9 ft-lb)
Primary shaft lock bolt	8.0-10.0 kg-m (60-72 ft-lb)

**SPECIFICATIONS**

		STANDARD	SERVICE LIMIT
Electric Starter	Drive gear O.D.	47.175–47.200 mm (1.8573–1.8583 in)	47.155 mm (1.8565 in)
	Idle gear I.D.	10.000–10.015 mm (0.3937–0.3943 in)	10.04 mm (0.395 in)
	Idle gear shaft O.D.	11.966–11.984 mm (0.4711–0.4718 in)	11.95 mm (0.470 in)
	Idle gear-to-shaft clearance	—————	0.10 mm (0.004 in)
Crankshaft	Connecting rod big end side clearance	0.05–0.20 mm (0.002–0.008 in)	0.3 mm (0.01 in)
	Runout	—————	0.05 mm (0.002 in)
	Crankpin oil clearance	0.020–0.060 mm (0.0008–0.0024 in)	0.08 mm (0.003 in)
	Main journal oil clearance	0.020–0.060 mm (0.0008–0.0024 in)	0.08 mm (0.003 in)
Cam chain	Length at 13 kg tension	315.40–315.74 mm (12.417–12.430 in)	318.2 mm (12.53 in)
Primary chain	Length at 36 kg tension	139.3–139.5 mm (5.48–5.49 in)	140.9 mm (5.55 in)

**TROUBLESHOOTING**
**Excessive noise**

- Worn main journal bearing
- Worn crank pin bearing



### PRIMARY SHAFT REMOVAL

Remove the starting motor (Section 20).  
Remove the A.C. generator (Section 18).  
Loosen the primary shaft drive gear lock bolt (Section 8).  
Disassemble the crankcase (Section 11).  
Remove the transmission assembly (Section 12).

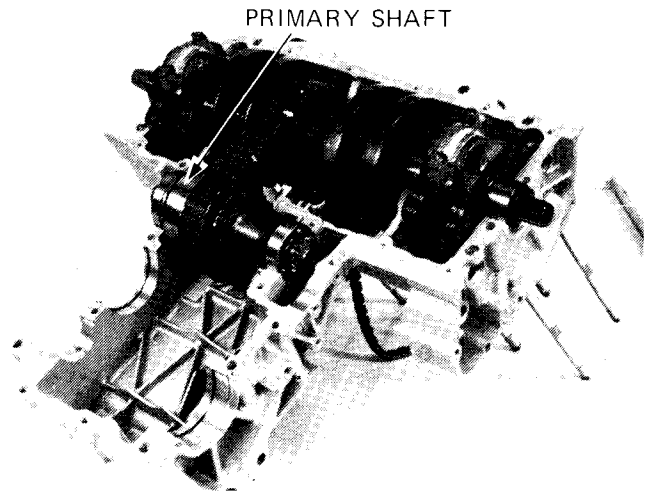

Raise the primary shaft assembly and remove the primary chain.

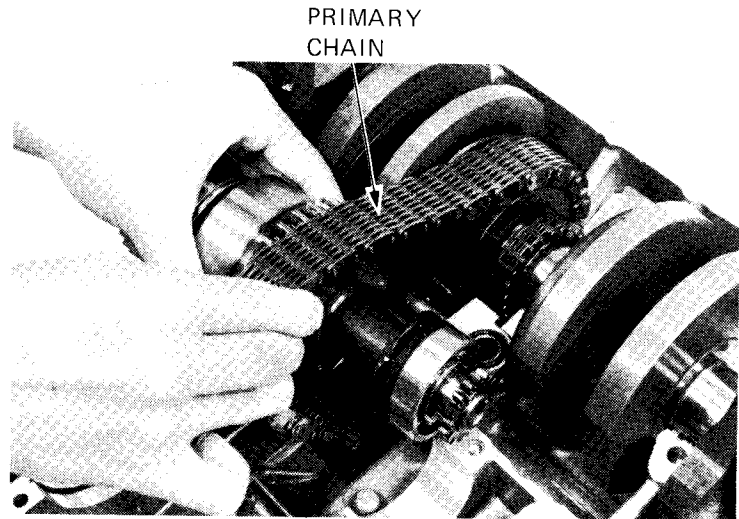

### PRIMARY SHAFT DISASSEMBLY

Remove the bearing.

### PRIMARY SHAFT INSPECTION

Check for scoring, wear or other damage.

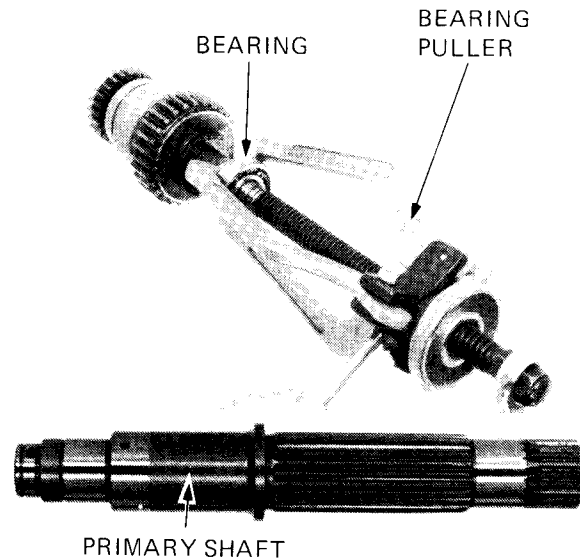



## PRIMARY CHAIN TENSIONER DISASSEMBLY

Remove the spring and plunger.  
 Remove the nut, tensioner fluid valve and oil line.  
 Remove the slipper assembly.

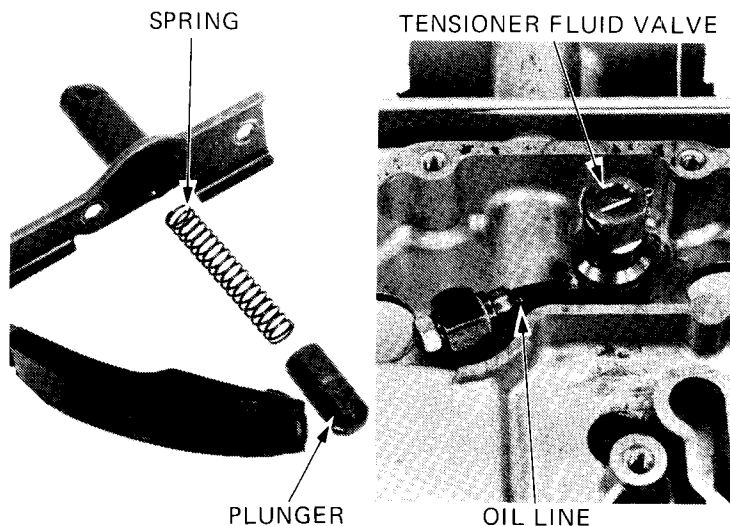

## INSPECTION

Check the holes in the oil line and plunger for blockage.  
 Clean all parts with non-flammable or high flash point solvent.  
 Inspect the slipper for damage or excessive wear.

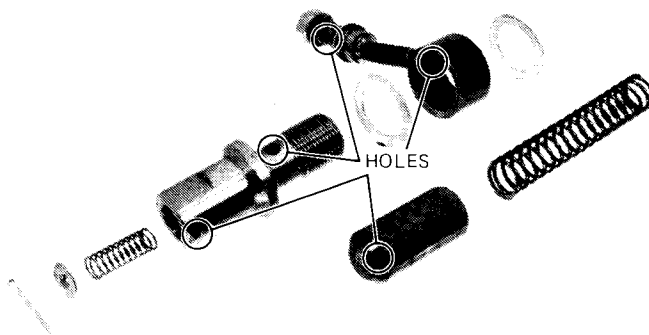

## CONNECTING ROD REMOVAL

Check the connecting rod side clearance.

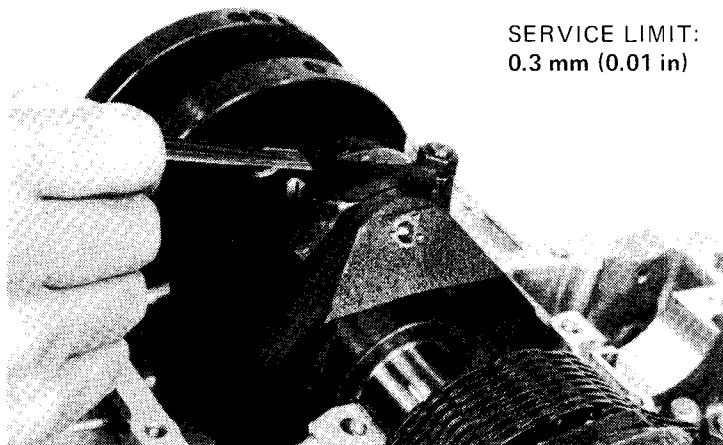

SERVICE LIMIT:  
 0.3 mm (0.01 in)



Remove the bearing caps and rods.

BEARING  
CAPS

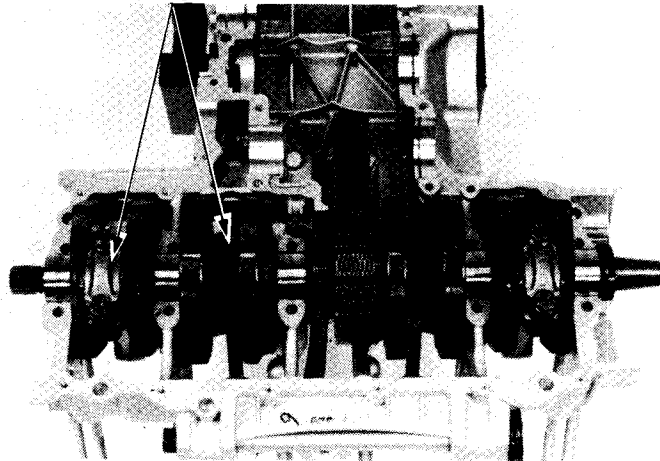

**NOTE**

Mark the rods, bearings and bearing caps to indicate cylinder position.



**CRANKSHAFT INSPECTION**

Remove the cam chain and primary chain.  
Set the crankshaft on a stand or V blocks.  
Set a dial indicator to the center main journal.  
Rotate the crankshaft two revolutions and read runout at the center journal.  
Actual runout is 1/2 of Total Indicator Reading.

SERVICE LIMIT:  
0.05 mm (0.002 in)

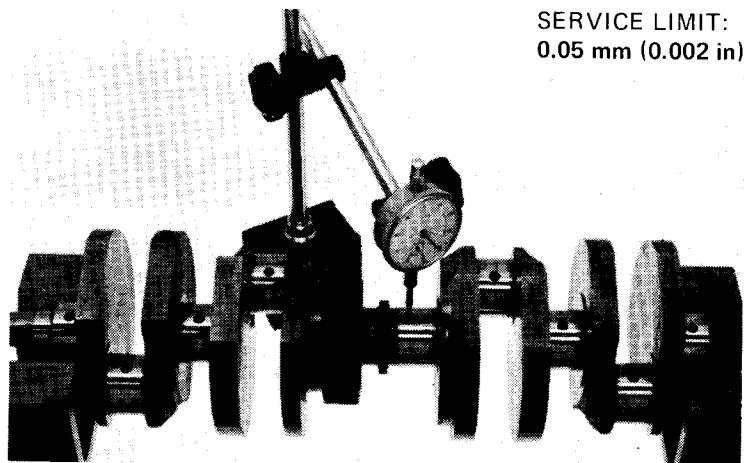



### CAM CHAIN LENGTH MEASUREMENT

Place the cam chain over the intake cam sprockets.

Secure one sprocket. Apply 13 kg (29 lb) of tension with a spring scale to the other sprocket.

Measure the chain length as shown.

**SERVICE LIMIT: 318.2 mm (12.53 in)**

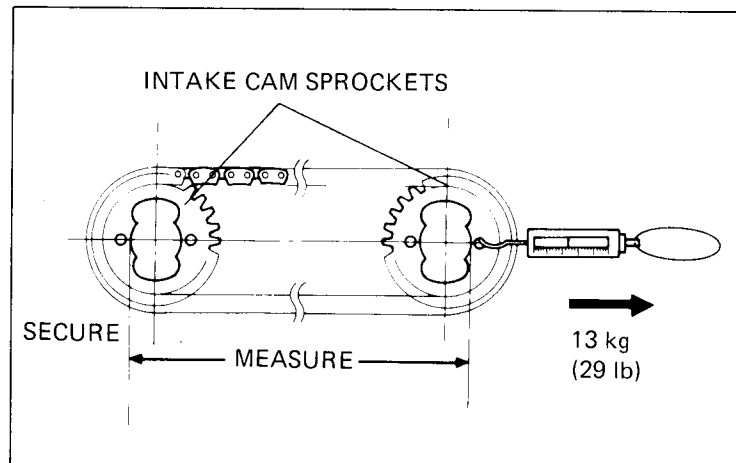

### PRIMARY CHAIN LENGTH MEASUREMENT

Place the primary chain over the primary driven gears. Secure one gear.

Apply 36 kg (79 lb) of tension with a spring scale to the other gear. Measure the chain length as shown.

**SERVICE LIMIT: 140.9 mm (5.54 in)**

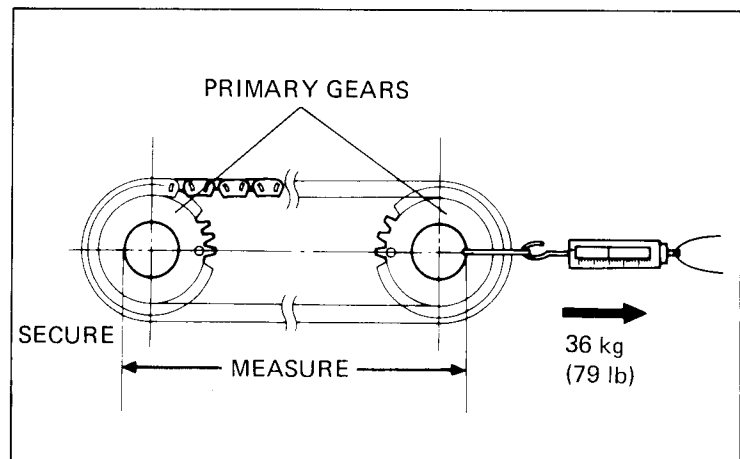

## BEARING INSPECTION

### CONNECTING RODS

Inspect the bearing inserts for damage or separation.

Clean all oil from the bearing inserts and crankpins.

Put a piece of plastigauge on each crankpin avoiding the oil hole.

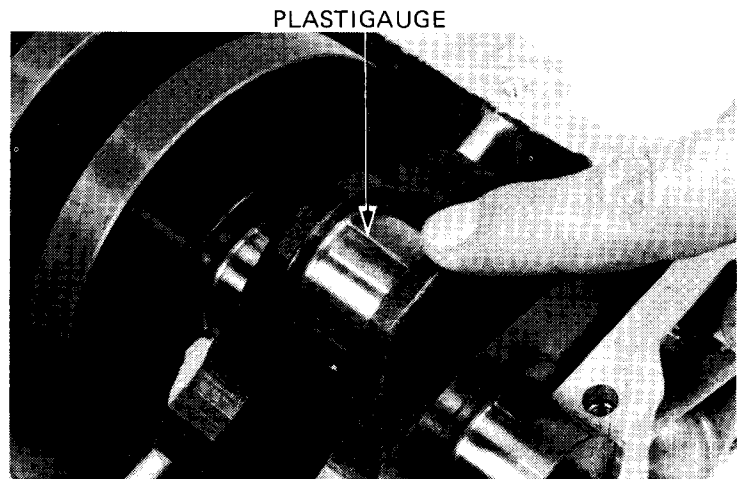



Install the bearing caps and rods on the correct crankpins, and tighten them evenly.

**TORQUE: 3.2 kg-m (23 ft-lb)**

**NOTE**

Do not rotate the crankshaft during inspection.

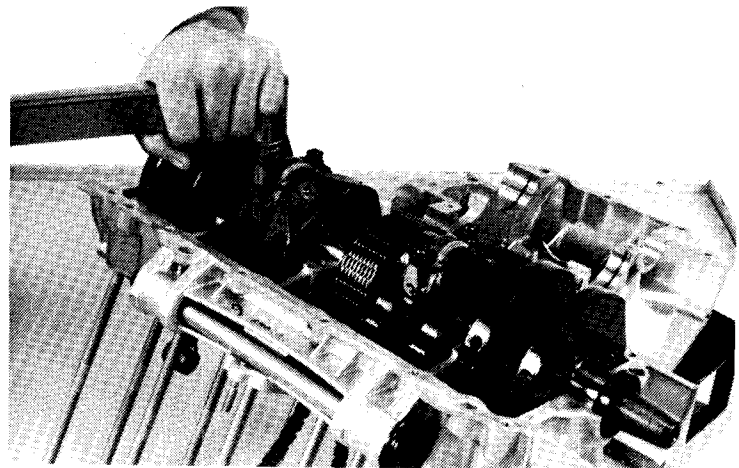

Remove the caps and measure the compressed plastigauge on each crankpin.

**OIL CLEARANCE SERVICE LIMIT:**  
0.08 mm (0.003 in)

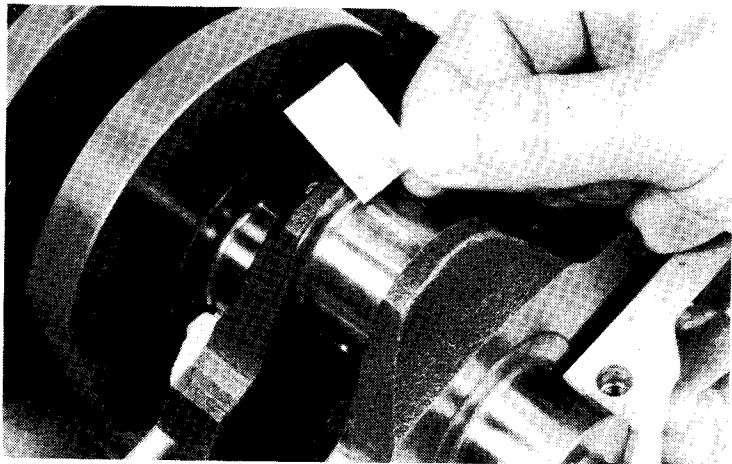

**MAIN BEARINGS**

Inspect the bearing inserts for damage or separation.

Clean all oil from the bearing inserts and journals.

Put a piece of plastigauge on each journal, avoiding the oil holes.

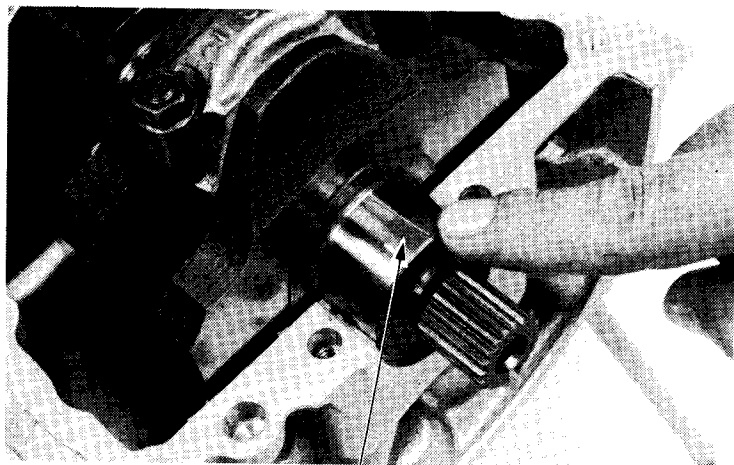

PLASTIGAUGE





Install the main bearings on the correct journals on the lower crankcase and tighten them evenly in the sequence shown and in 2-3 steps.

**TORQUE VALUES:**

8 mm bolt (Crankshaft)	2.1–2.5 kg-m (15–18 ft-lb)
8 mm bolt (Crankcase)	2.1–2.5 kg-m (15–18 ft-lb)
6 mm bolt	1.0–1.4 kg-m (7–10 ft-lb)
10 mm bolt	4.5–5.0 kg-m (33–36 ft-lb)

**NOTE**

Do not rotate the crankshaft during inspection.

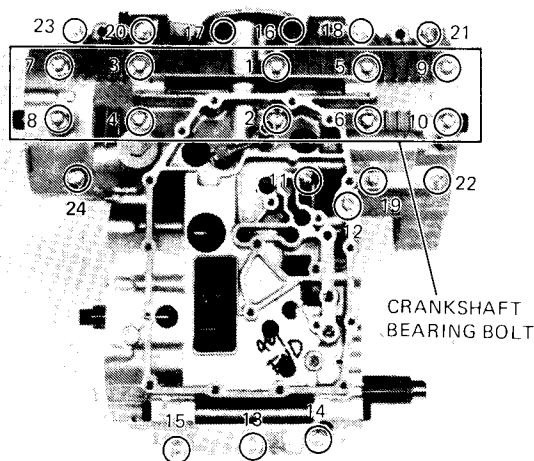

Remove the lower crankcase and measure the compressed plastigauge on each journal.

**OIL CLEARANCE SERVICE LIMIT:**  
0.08 mm (0.003 in)

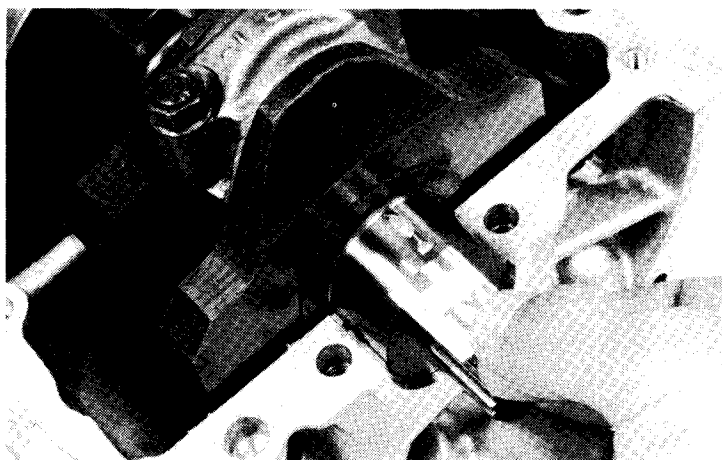

**BEARING SELECTION**

If rod bearing clearance is beyond tolerance, select replacement bearings as follows:

**CONNECTING ROD BEARING INSERTS**

Determine and record the corresponding rod I.D. code number.

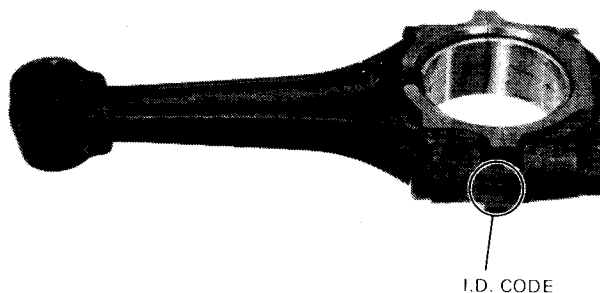



Determine and record the corresponding crankpin O.D. code number (or measure the crankpin O.D.).

### NOTE

Number 1, 2 or 3 on each crank weight is the code for each crankpin O.D.

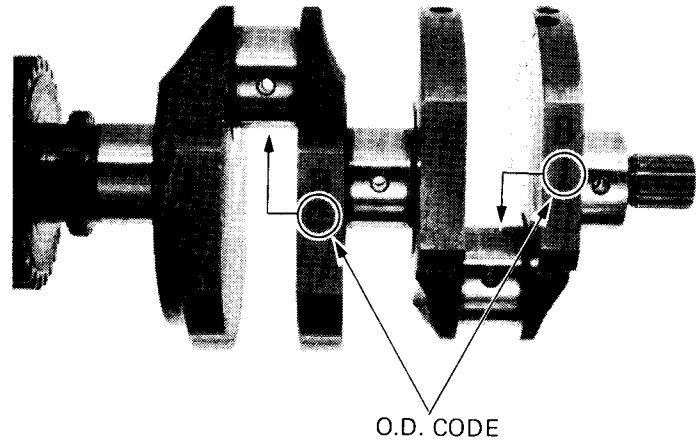

Cross reference the crankpin and rod codes to determine the replacement bearing color.

		CRANKPIN O.D. CODE NO.			
		1	2	3	
CONNECTING ROD I.D. CODE NO.	1	39.000–39.008 mm	E (Yellow)	D (Green)	C (Brown)
	2	39.008–39.016 mm	D (Green)	C (Brown)	B (Black)
	3	39.016–39.024 mm	C (Brown)	B (Black)	A (Blue)

### BEARING INSERT THICKNESS:

- A (Blue) : 1.502–1.506 mm (0.0591–0.0593 in)
- B (Black) : 1.498–1.502 mm (0.0590–0.0591 in)
- C (Brown) : 1.494–1.498 mm (0.0588–0.0590 in)
- D (Green) : 1.490–1.494 mm (0.0587–0.0588 in)
- E (Yellow) : 1.486–1.490 mm (0.0585–0.0587 in)

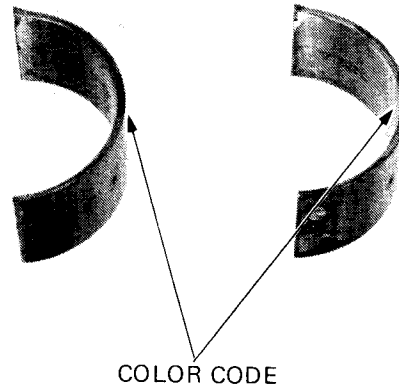

### MAIN BEARING

Determine and record crankcase I.D. code numbers.

### NOTE

Letters A, B or C on the upper rear crankcase are the codes for the main journal I.D. from left to right; I.D. code for the third main journal from left to right is B.

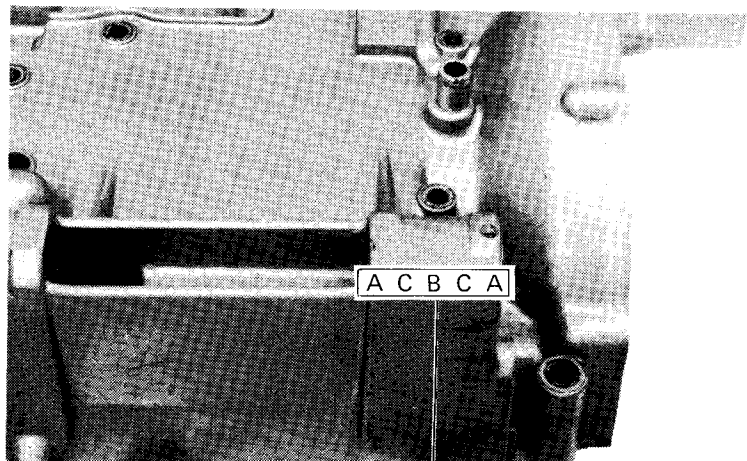

I.D. CODE



Determine and record the corresponding main journal O.D. code letters (or measure the main journal O.D.).

**NOTE**

Letter A, B or C on each crank weight is the code for the adjacent main journal O.D.

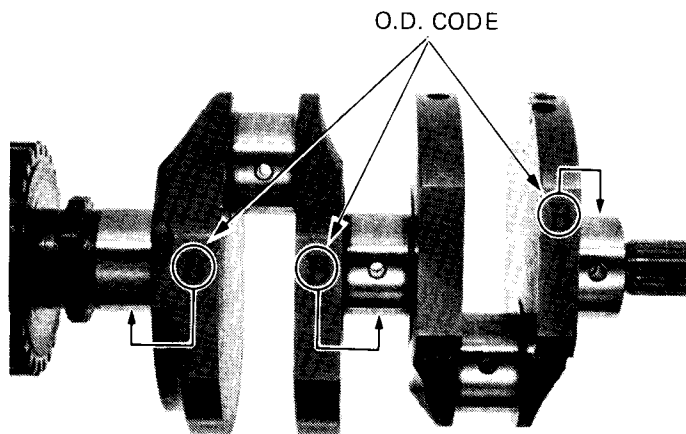

Cross reference the case and journal codes to determine the replacement bearing.

		MAIN JOURNAL O.D. CODE NO.			
		A	B	C	
CASE I.D. CODE NO.	A	39.000–39.008 mm	D (Yellow)	C (Green)	B (Brown)
	B	39.008–39.016 mm	C (Green)	B (Brown)	A (Black)
	C	39.016–39.024 mm	B (Brown)	A (Black)	E (Blue)

**MAIN BEARING INSERT THICKNESS:**

- A (Black) : 1.498–1.502 mm (0.0590–0.0591 in)
- B (Brown) : 1.494–1.498 mm (0.0588–0.0590 in)
- C (Green) : 1.490–1.494 mm (0.0587–0.0588 in)
- D (Yellow) : 1.486–1.490 mm (0.0585–0.0587 in)
- E (Blue) : 1.502–1.506 mm (0.0591–0.0593 in)

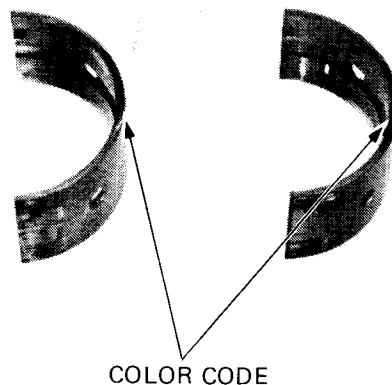

**CONNECTING ROD INSTALLATION**

Install the main bearings into the upper crankcase.

Apply molybdenum disulfide grease to the upper and lower main bearings.

Install the crankshaft with the cam chain and primary chain.

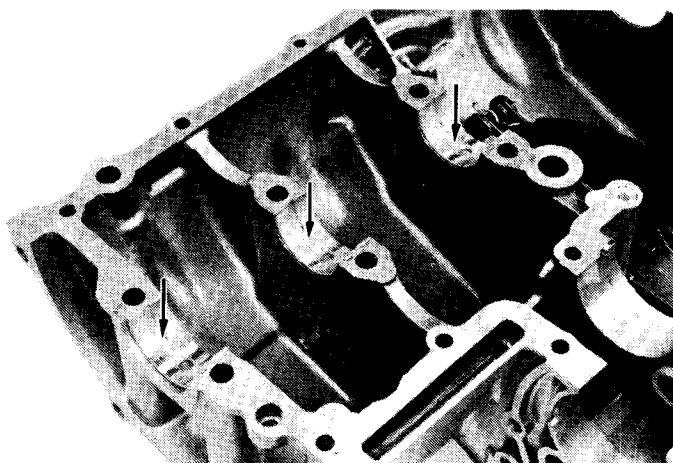



Before installing the connecting rods, make sure that the weight code combination is properly made:

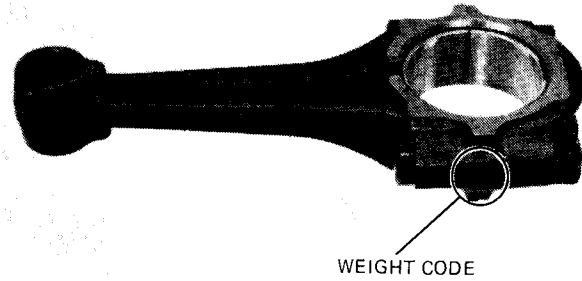
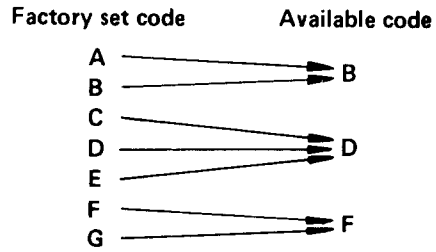

Align the hole in the bearing insert with the hole in the connecting rod.

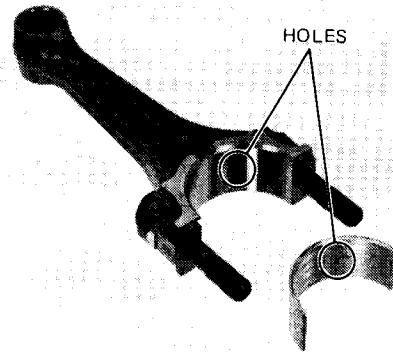

Install the connecting rod and cap bearing inserts.

Apply molybdenum disulfide grease to the connecting rod bearings.

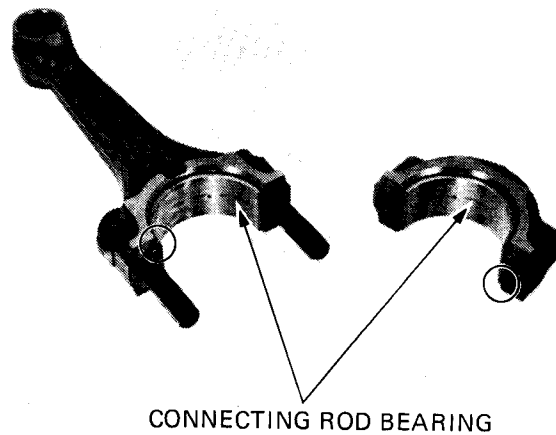



**180 CRANKSHAFT/PRIMARY SHAFT**

Install the connecting rods and bearing caps.

**NOTE**

- Be sure connecting rods are installed in their correct position and the oil holes point to the rear.
- Cross reference the rod and cap I.D. codes to insure original assembly.

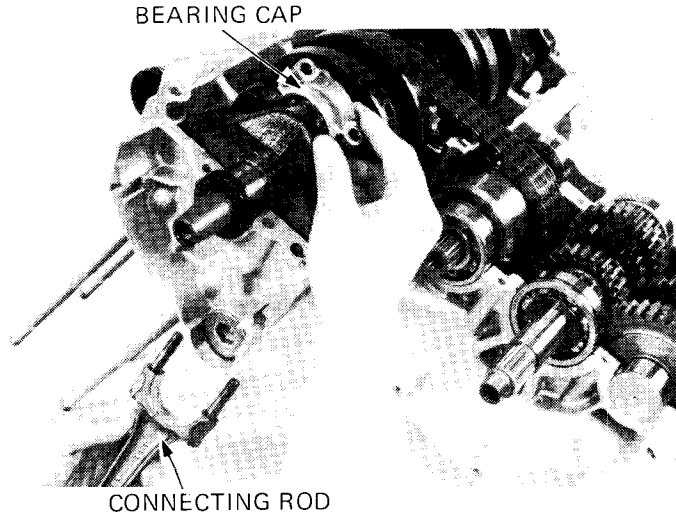

Tighten the connecting rod bearing cap bolts.

**TORQUE: 3.2 kg-m (23 ft-lb)**

**NOTE**

- Tighten the rod bearing cap bolts in two or more steps.
- After tightening the bolts, check that the rod moves freely without binding.

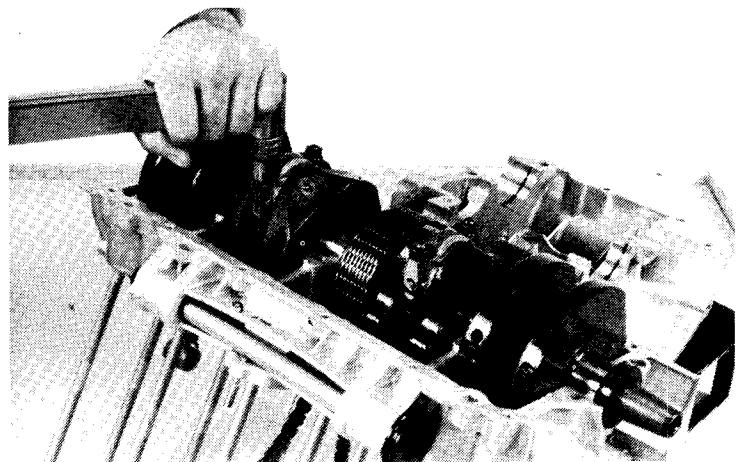

**PRIMARY SHAFT ASSEMBLY**

Insert the bearing into the primary shaft.

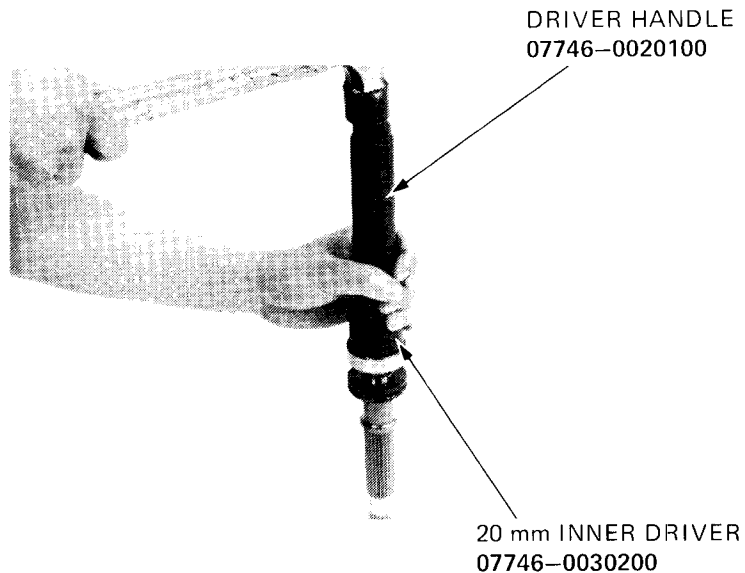



Install the damper and bearings.  
Tighten the lock bolt (Section 8).

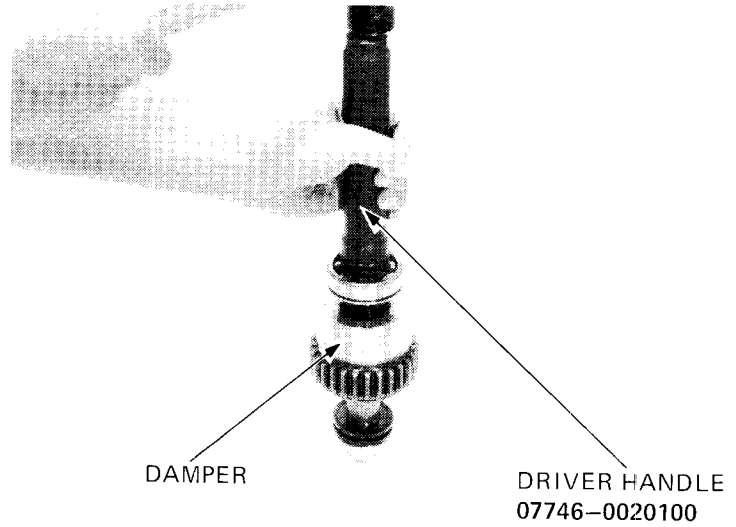

### PRIMARY CHAIN TENSIONER ASSEMBLY

Install the slipper base.  
Tighten the bolts securely.  
Insert the spring and plunger.  
Press the slipper down and install the pin.

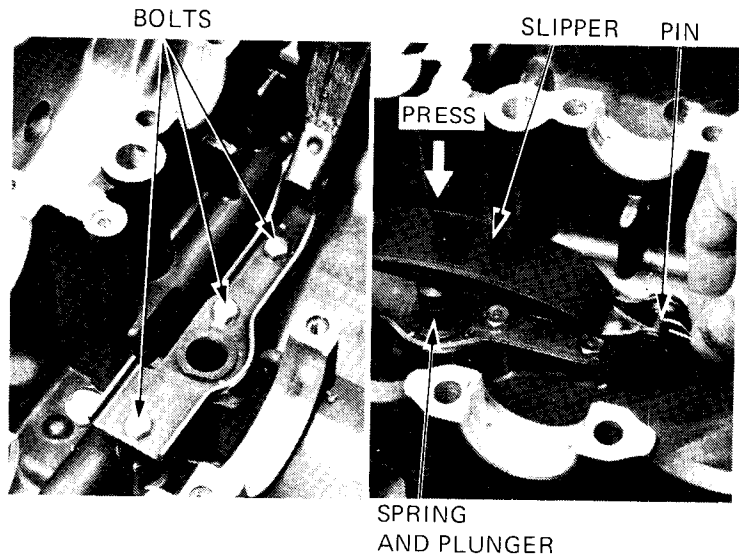

Install the fluid valve and oil line. Tighten the nut.  
Insert the spring and plunger.  
Install the cotter pin as shown.

