



SERVICE INFORMATION	12-1
TROUBLESHOOTING	12-2
TRANSMISSION DISASSEMBLY	12-3
SHIFT FORK AND SHIFT DRUM	12-5
TRANSMISSION ASSEMBLY	12-8

SERVICE INFORMATION

GENERAL INSTRUCTIONS

- The gear shift linkage can be serviced with the engine in the frame (Section 9).
- For internal transmission repairs, the crankcase must be separated (Section 11).

TOOLS

Common

Driver Handle B	07746-0020100	or 07945-3230201
Driver Handle C	07746-0030100] or 07945-3710200
25 mm Inner Driver	07746-0030200	

SPECIFICATIONS

Transmission			STANDARD	SERVICE LIMIT
Backlash	low, 2nd		0.021- 0.110 mm (0.0008-0.0043 in)	0.15 mm (0.006 in)
	3rd, 4th, 5th		0.023- 0.117 mm (0.0009-0.0046 in)	0.15 mm (0.006 in)
Gear I.D.	M4 gear		28.020-28.041 mm (1.1031-1.1040 in)	28.06 mm (1.105 in)
	M5 gear		31.025-31.050 mm (1.2215-1.2224 in)	31.07 mm (1.223 in)
	C1 gear		25.000-25.021 mm (0.9843-0.9851 in)	25.06 mm (0.987 in)
	C3 gear		28.020-28.041 mm (1.3031-1.1040 in)	28.07 mm (1.105 in)
Gear bushing	M5 O.D.		30.950-30.975 mm (1.2185-1.2195 in)	30.93 mm (1.218 in)
	C1 O.D.		24.959-24.980 mm (0.9826-0.9835 in)	24.93 mm (0.981 in)
	C1 I.D.		22.010-22.031 mm (0.8665-0.8673 in)	22.06 mm (0.869 in)
Mainshaft O.D.	at M4		27.959-27.980 mm (1.1007-1.1016 in)	27.930 mm (1.0996 in)
Countershaft O.D.	at C1 bushing		21.987-22.000 mm (0.8656-0.8661 in)	21.930 mm (0.8634 in)
	at C3		27.959-27.980 mm (1.1007-1.1016 in)	27.941 mm (1.1000 in)
Gear to bushing or shaft clearance	M4 to shaft		0.040- 0.082 mm (0.0016-0.0032 in)	0.10 mm (0.004 in)
	M5 to M5 bushing		0.050- 0.100 mm (0.0020-0.0039 in)	0.12 mm (0.005 in)
	C1 to C1 bushing		0.010- 0.0044 mm (0.0004-0.0017 in)	0.10 mm (0.004 in)
	C1 bushing to shaft		0.020- 0.062 mm (0.0008-0.0024 in)	0.10 mm (0.004 in)
	C3 to shaft		0.040- 0.082 mm (0.0016-0.0032 in)	0.10 mm (0.004 in)



		STANDARD	SERVICE LIMIT	
Shift fork	Claw thickness	6.43–6.50 mm (0.253–0.256 in)	6.1 mm (0.24 in)	
	I.D.	Center	13.000–13.018 mm (0.5118–0.5125 in)	13.04 mm (0.513 in)
		Left and right	13.000–13.018 mm (0.5118–0.5125 in)	13.04 mm (0.513 in)
Fork shaft	O.D.	12.966–12.984 mm (0.5104–0.5112 in)	12.90 mm (0.508 in)	

TROUBLESHOOTING

Hard to shift

1. Improper clutch adjustment: too much free play
2. Shift fork bent
3. Shift shaft bent
4. Shift claw bent
5. Shift drum cam grooves damaged

Transmission jumps out of gear

1. Gear dogs worn
2. Shift shaft bent
3. Shift drum stopper broken
4. Shift forks bent



For servicing of the gearshift linkage, see Section 9.

TRANSMISSION DISASSEMBLY

Separate the crankcase (Section 11).
Inspect each gear for backlash.

SERVICE LIMIT: 0.15 mm (0.006 in)

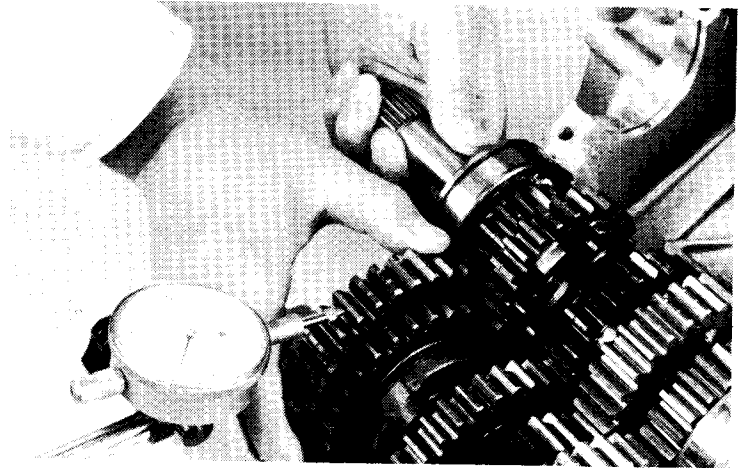

Remove the mainshaft and countershaft.
Remove the dowel pins from the crankcase.

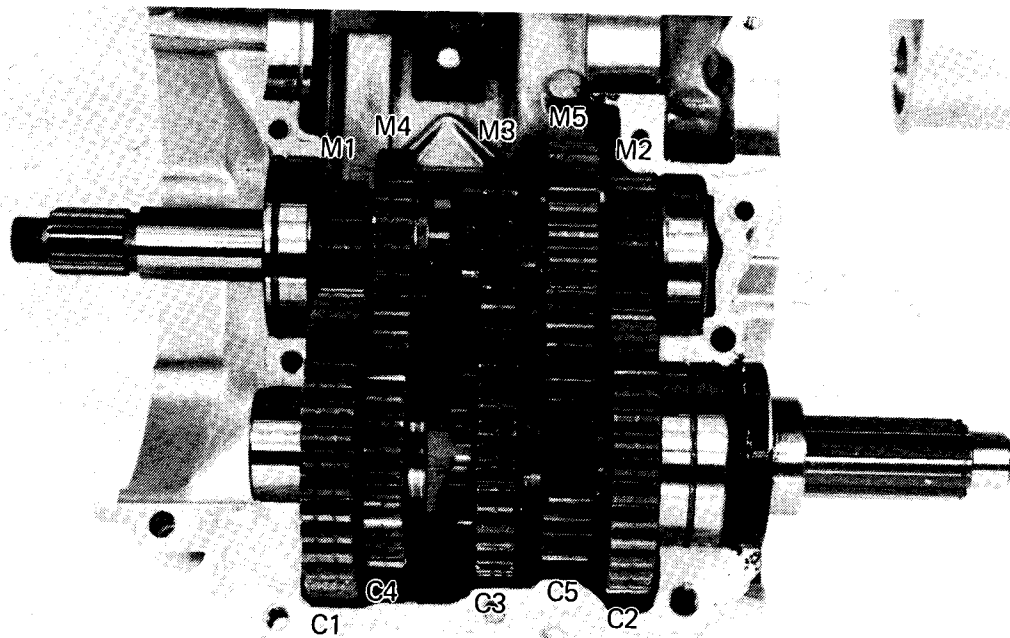



TRANSMISSION INSPECTION

Check gear dogs, dog holes and teeth for excessive or abnormal wear, or evidence of insufficient lubrication.

Measure the I.D. of each gear.

SERVICE LIMITS:

- M4 gear: 28.06 mm (1.105 in)
- M5 gear: 31.07 mm (1.113 in)
- C1 gear: 25.06 mm (0.987 in)
- C3 gear: 28.07 mm (1.105 in)

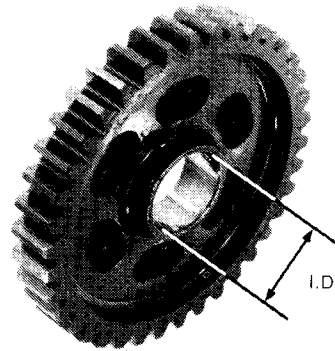

Measure the I.D. and O.D. of the gear bushings.

SERVICE LIMITS:

- M5 O.D.: 30.93 mm (1.218 in)
- C1 O.D.: 24.93 mm (0.981 in)
- C1 I.D.: 22.06 mm (0.869 in)

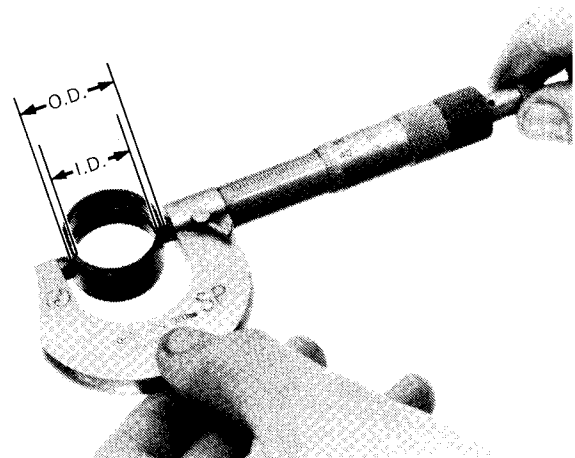

Measure the O.D. of the mainshaft and countershaft.

SERVICE LIMITS:

- A (at M4 gear) : 27.930 mm (1.0996 in)
- B (at C3 gear) : 27.941 mm (1.1000 in)
- C (at C1 bushing) : 21.930 mm (0.8634 in)

Calculate the clearance between the gear and gear shaft or bushing.

SERVICE LIMITS:

- M5 to M5 bushing : 0.12 mm (0.005 in)
- M4 to shaft : 0.10 mm (0.004 in)
- C1 to C1 bushing : 0.10 mm (0.004 in)
- C1 bushing to shaft : 0.10 mm (0.004 in)
- C3 to shaft : 0.10 mm (0.004 in)

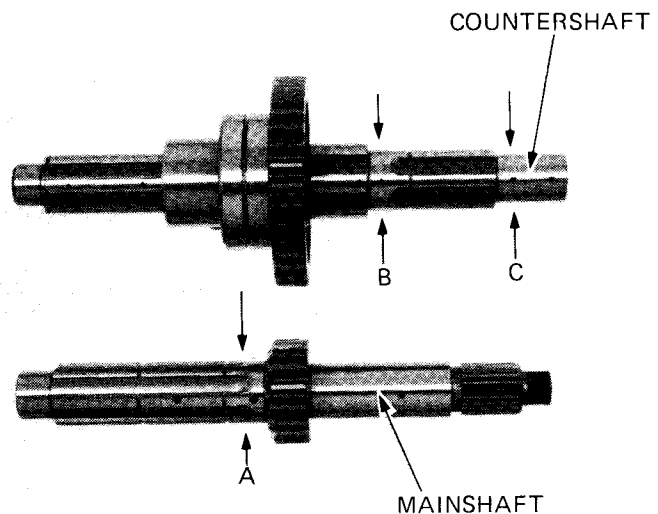



SHIFT FORK AND SHIFT DRUM

REMOVAL

Remove the bearing stopper plate.

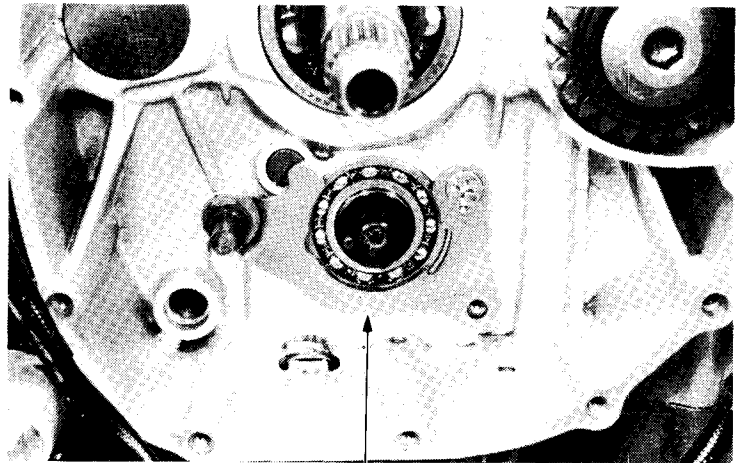

BEARING STOPPER PLATE

Remove the shift fork shaft and shift forks.
Remove the shift drum.

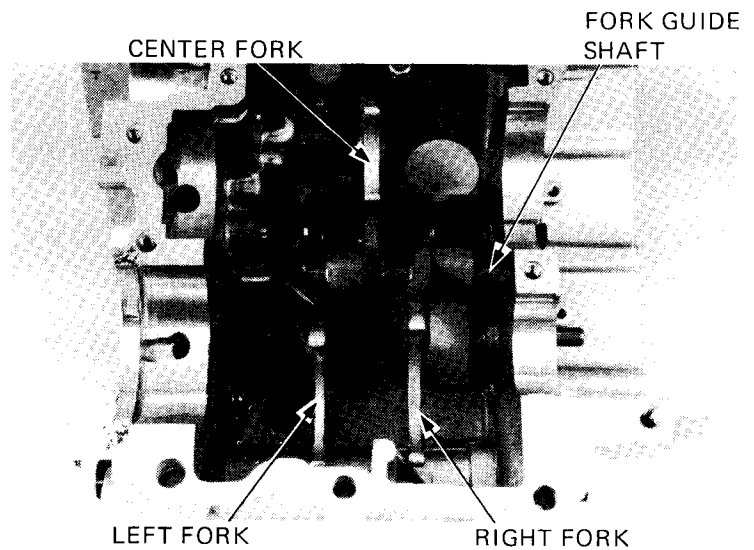

GEAR SHIFT DRUM AND SHIFT FORK INSPECTION

Inspect the shift drum end for scoring, scratches, or evidence of insufficient lubrication.

Check the shift drum grooves for damage.

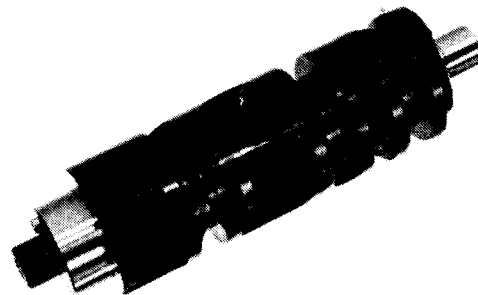



162 TRANSMISSION

Inspect the shift drum hole and shift fork shaft hole for scoring or scratches.

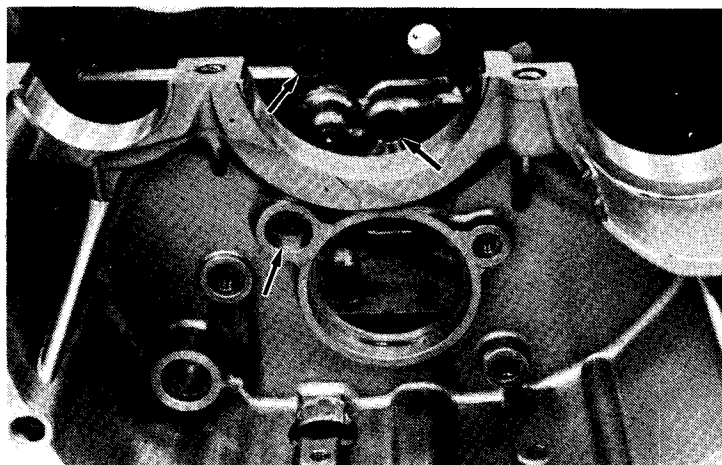

Measure the shift fork shaft O.D.
Check for scratches, scoring, or evidence of insufficient lubrication.

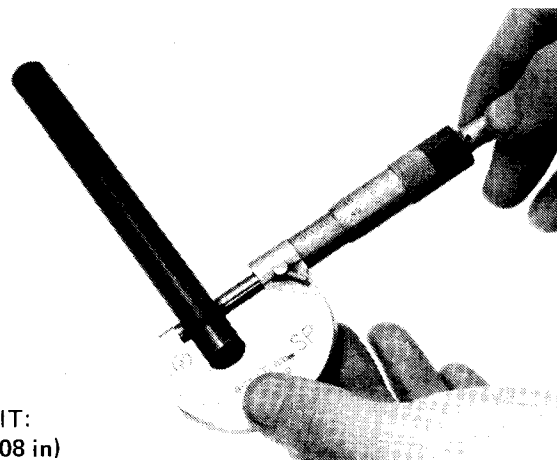

SERVICE LIMIT:
12.90 mm (0.508 in)

Measure the shift fork I.D. and claw thickness.

SERVICE LIMITS:

I.D.: 13.04 mm (0.513 in)
CLAW THICKNESS: 6.1 mm (0.24 in)

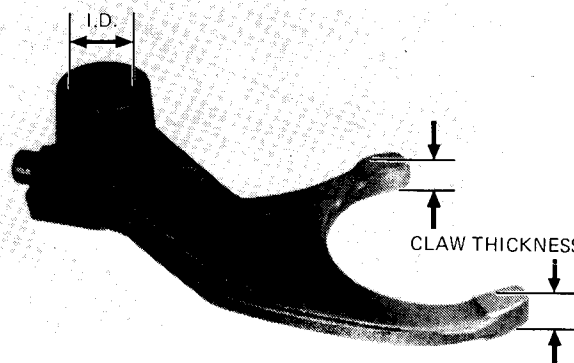



INSTALLATION

Install the shift drum and shift fork, by reversing the removal procedure. Key points are shown here.

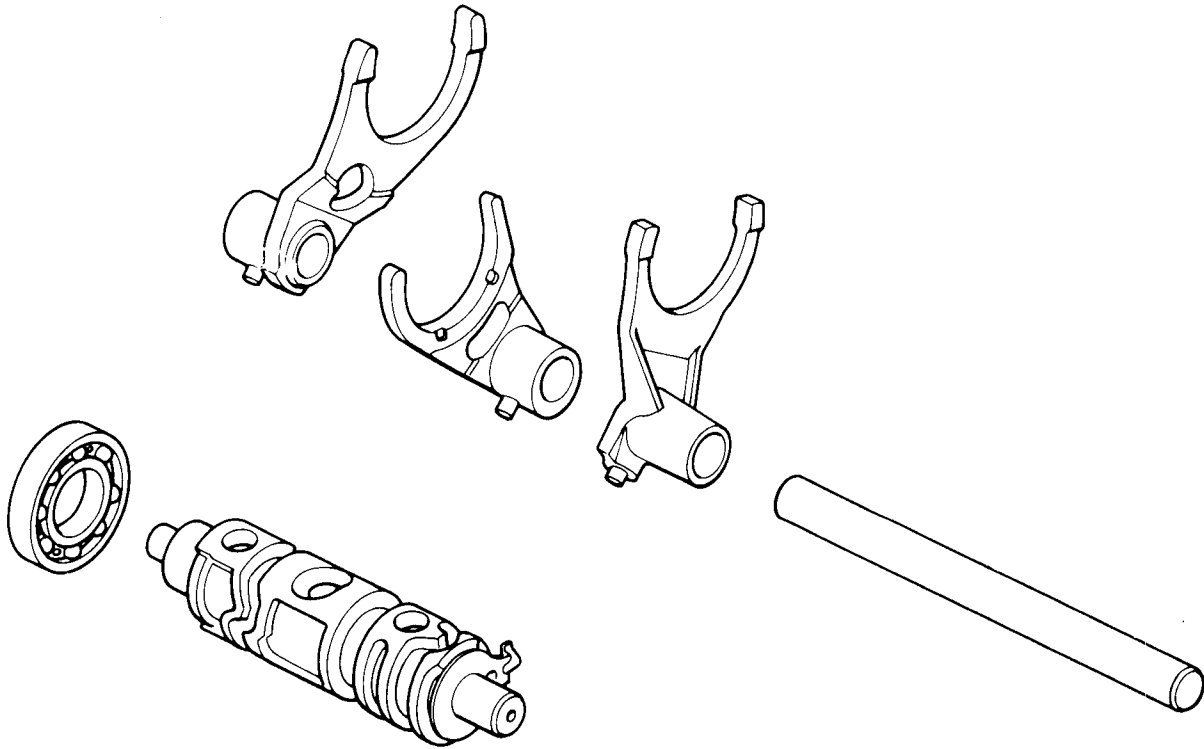

CAUTION:

When installing the bearing stopper plate, apply a locking agent to the screw threads.

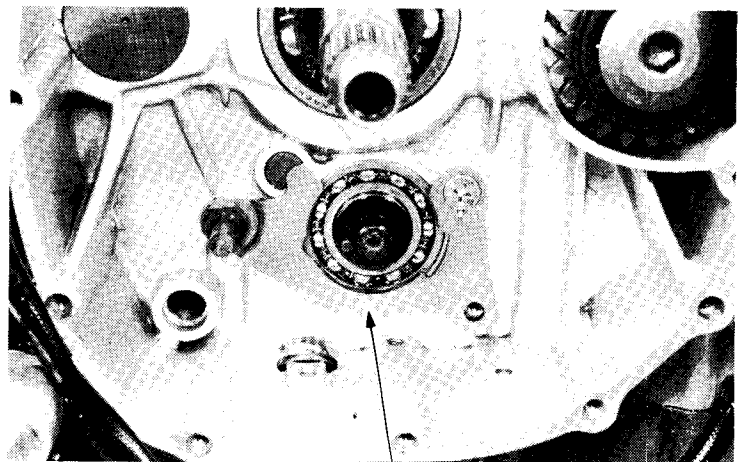

BEARING STOPPER PLATE



TRANSMISSION ASSEMBLY

Assemble the mainshaft and countershaft.

NOTE

- Check the gears for freedom of movement or rotation on the shaft.
- Check that the snap rings are seated in the grooves.

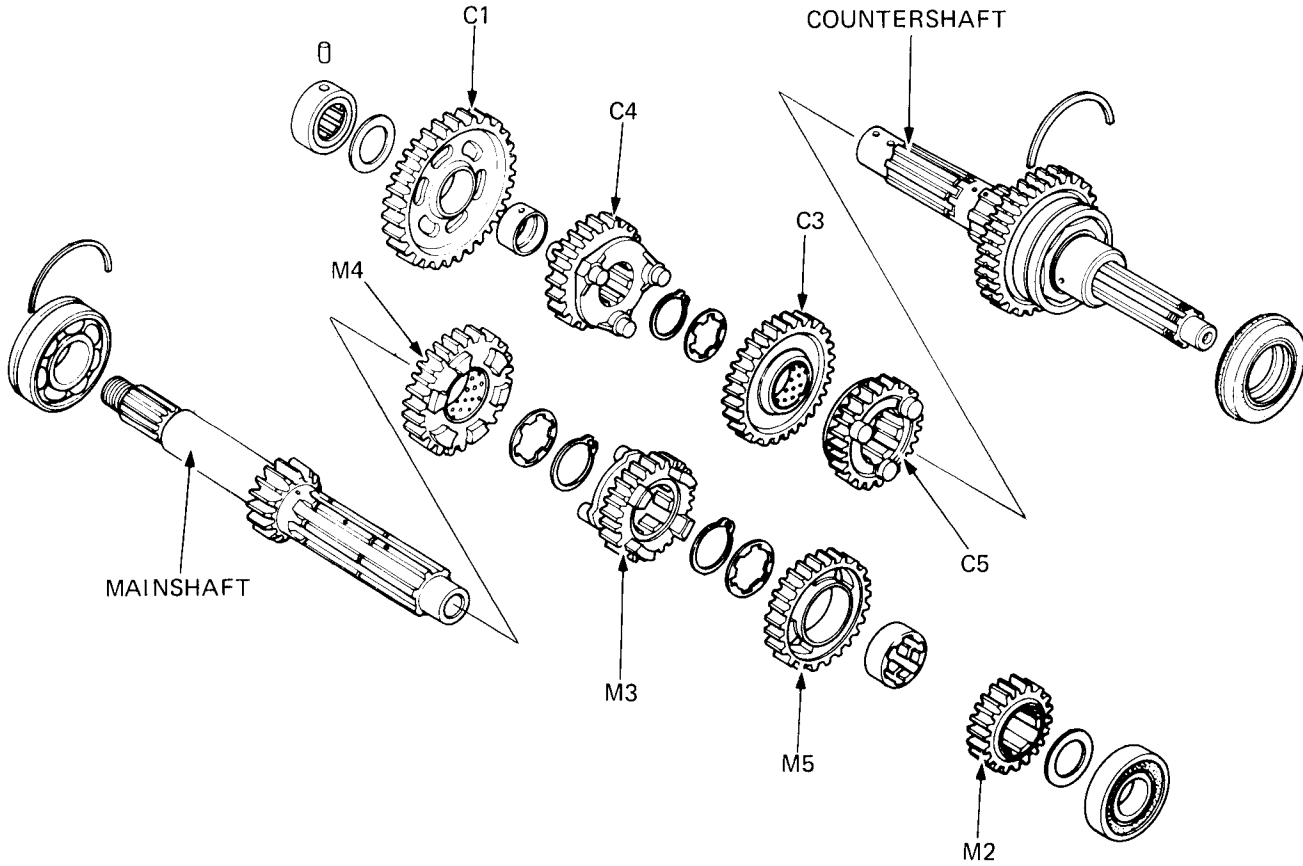

Install the mainshaft bearing with tools.

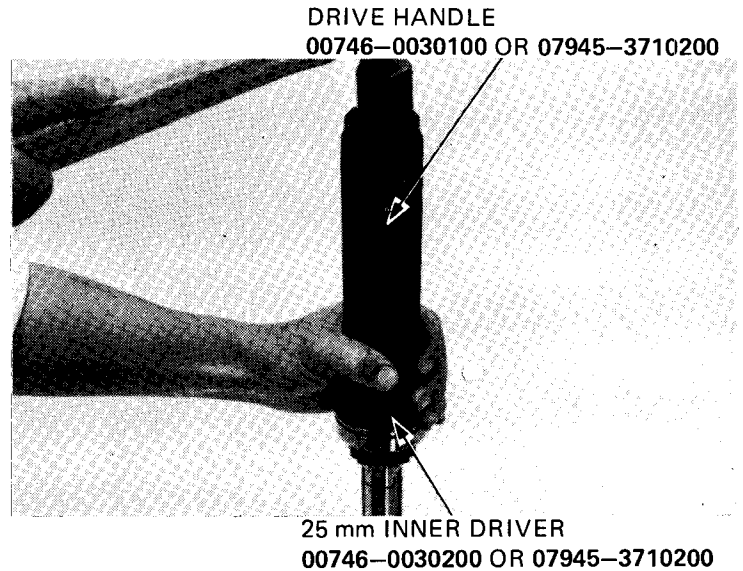



Align the hole in the M5 gear bushing with the hole in the mainshaft.

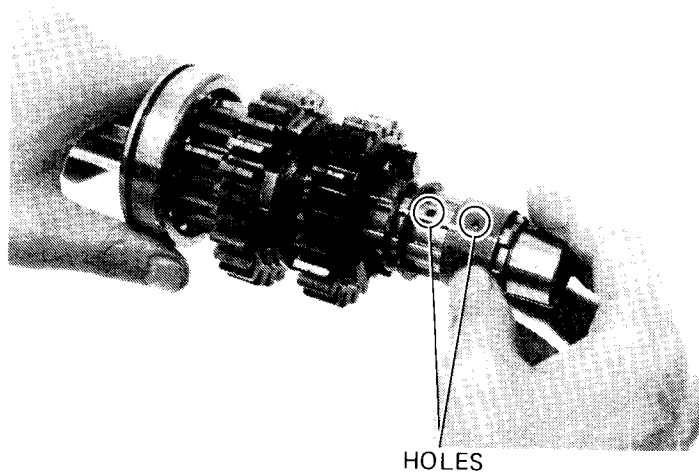

Align the hole in the C5 gear with the hole in the countershaft.

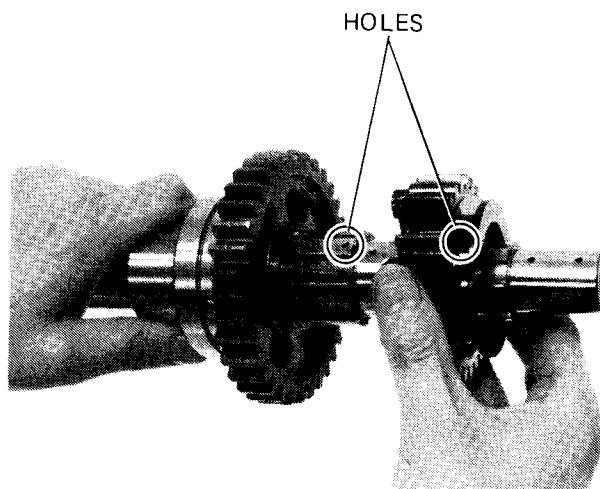

Insert the dowel pin.

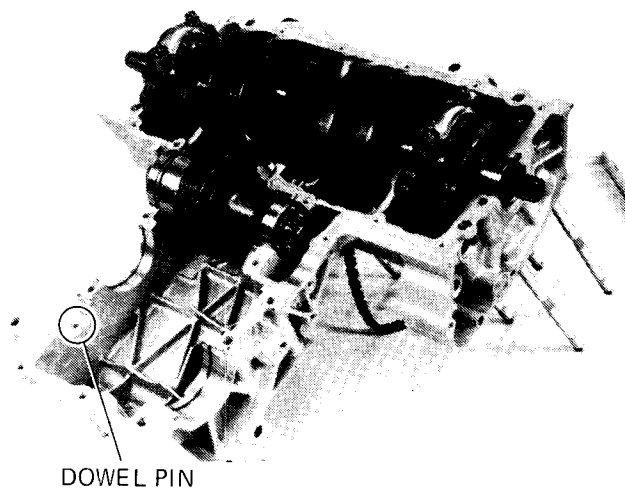

Align the hole in the countershaft bearing with the dowel pin.

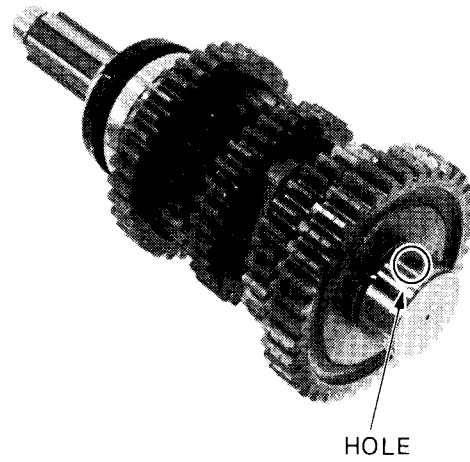

NOTE

Push the countershaft oil seal in until the oil seal lip is seated completely on the bearing before assembling the lower crankcase to prevent oil leakage.

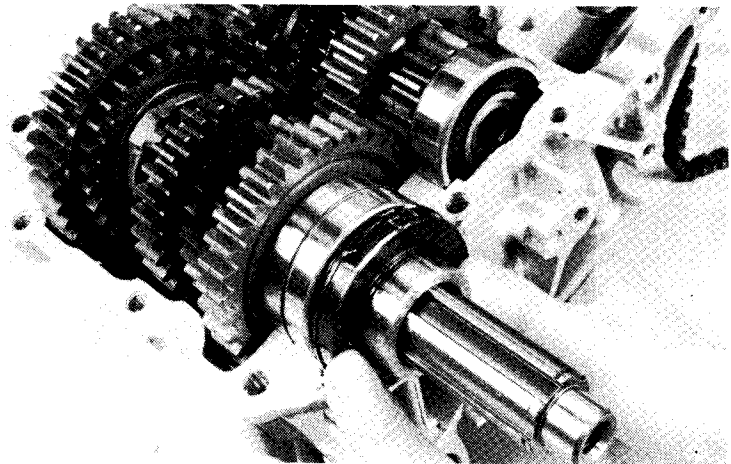

Install the lower crankcase (Refer to Section 11).

NOTE

Check the oil orifice for clogging, before installing the lower crankcase.

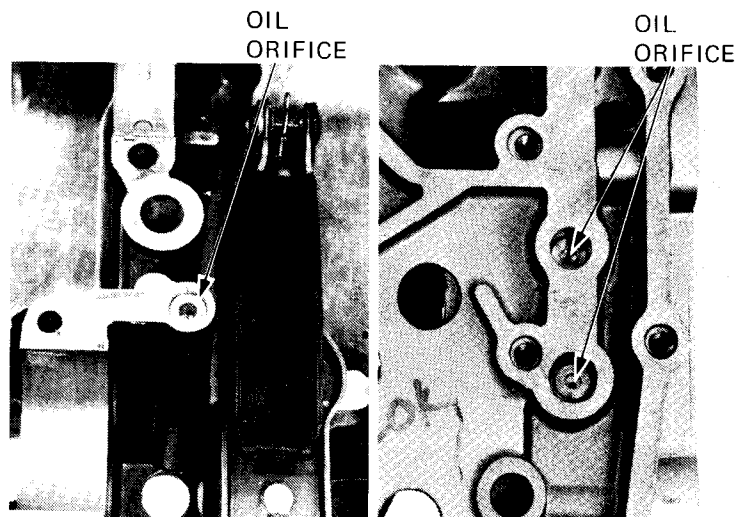



MEMO