



SERVICE INFORMATION	10- 1	SUBTRANSMISSION CASE	
TROUBLESHOOTING	10- 2	REMOVAL	10- 9
SUBTRANSMISSION DISASSEMBLY	10- 3	RETAINER B OIL SEAL	
SUBTRANSMISSION ASSEMBLY	10- 6	REPLACEMENT	10- 9
		SUBTRANSMISSION CASE	
		INSTALLATION	10-15

SERVICE INFORMATION

GENERAL INSTRUCTIONS

- These parts can be serviced with the subtransmission in the frame.
 - Reduction drive/driven gears and collars.
 - Damper lifter, spring and spring seat.
 - Gear shift linkage.
 - Subtransmission oil pump (see section 2).

- The swing arm and subtransmission must be removed to service these parts.
 - Subtransmission case and oil seal.

- Replace the subtransmission as an assembly if bearings, drive or driven gears need replacement.

TOOLS

Special

Retainer wrench A	07910-4610100	Not available in U.S.A.
Retainer wrench B	07910-4610200	
Damper compressor	07964-4610000	
Preload inspection tool	07998-4610000	
Subtransmission base	07965-4610000	Not available in U.S.A.

Common

Bearing driver handle A	07749-0010000	or 07949-6110000
Bearing driver outer		
37 x 40 mm	07746-0010200	
42 x 47 mm	07746-0010300	
Bearing driver handle C	07746-0030100	

SPECIFICATIONS

	STANDARD	SERVICE LIMIT
Reduction drive gear I.D.	31.000–31.025 mm (1.220–1.221 in)	31.04 mm (1.222 in)
Reduction drive gear collar O.D.	30.950–30.975 mm (1.218–1.219 in)	30.94 mm (1.218 in)
Reduction driven gear I.D.	25.000–25.021 mm (0.984–0.985 in)	25.04 mm (0.986 in)
Final drive gear shaft O.D.	24.959–24.980 mm (0.982–0.983 in)	24.95 mm (0.982 in)
Final drive gear damper spring free length	107.7 mm (4.24 in)	—
Final drive gear backlash	0.08 – 0.18 mm (0.003–0.007 in)	0.25 mm (0.010 in)
Shift fork claw thickness	6.00 – 6.10 mm (0.236–0.240 in)	5.7 mm (0.22 in)
Reduction gear backlash	0.072– 0.143 mm (0.003–0.006 in)	0.20 mm (0.008 in)

Subtransmission

Oil capacity 0.6 liter (0.61 US qt)
 Hypoid gear oil SAE #80

TORQUE VALUES

Subtransmission cover 3.0– 3.4 kg-m (22–25 ft-lb)
 Oil level check bolt 3.5– 4.0 kg-m (25–29 ft-lb)
 Oil drain bolt 1.6– 2.0 kg-m (12–14 ft-lb)
 Oil cap bolt 0.4– 0.6 kg-m (3– 4 ft-lb)
 Final drive gear ass'y. lock nut 9.5–10.5 kg-m (69–76 ft-lb)

TROUBLESHOOTING
Hard to shift

1. Improper clutch adjustment: too much free play
2. Shift fork bent
3. Shift shaft bent
4. Shift claw bent
5. Shift drum cam grooves damaged

Transmission jumps out of gear

1. Gear dogs worn
2. Shift shaft bent
3. Shift drum stopper broken
4. Shift forks bent

Final drive gear noise

1. Oil level too low
2. Excessive backlash
3. Drive shaft splines damaged or worn
4. Insufficient lubricant



SUBTRANSMISSION DISASSEMBLY

- Remove the foot pegs.
- Remove the exhaust pipe heat shield.
- Remove the select pedal and arm.
- Drain the oil (Page 2-9).
- Remove the cover.

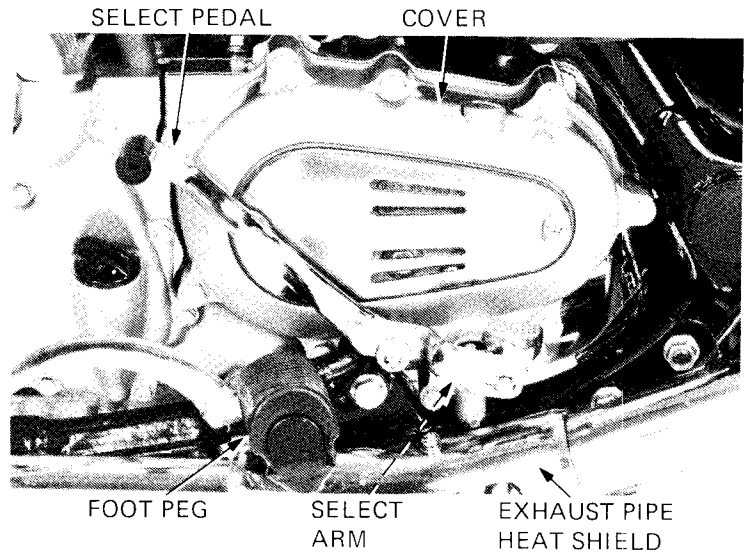

- Remove the circlip, washer and cotters.
- Remove the 43T reduction drive gear and collar.
- Remove the shift drum, shift fork and shifter with spline collar.
- Remove the collar, and the 47T reduction driven gear and washer.

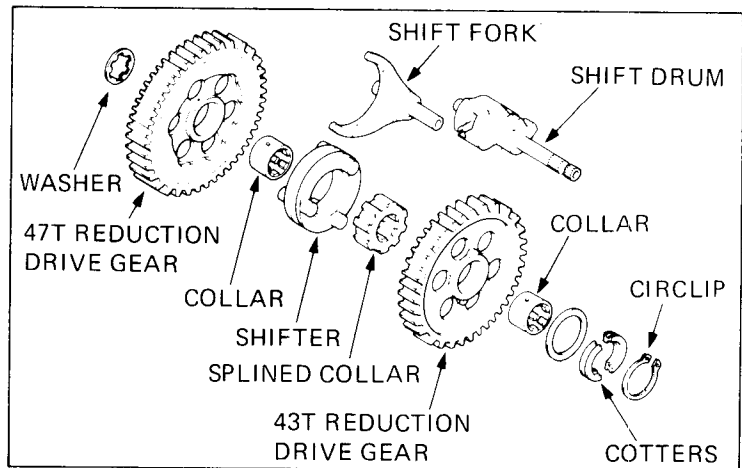

- Remove the shift drum stopper arm and spring.
- Remove the O-ring.

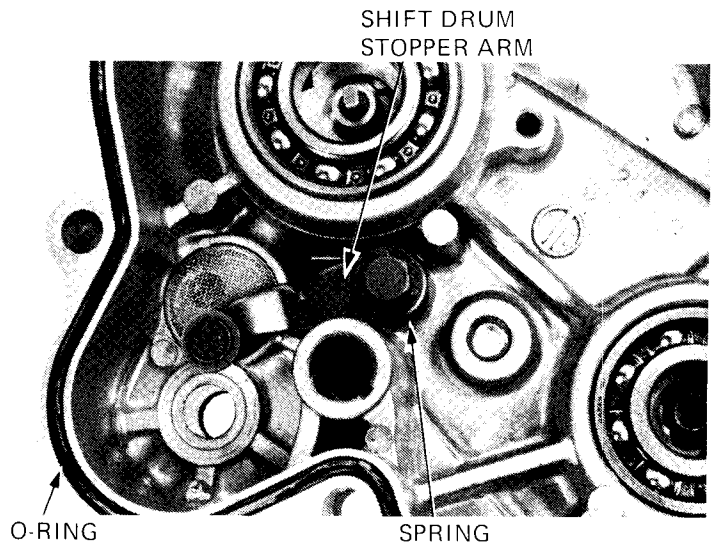



Compress the reduction driven gear with the special tool and remove the spring cotters.

After removing the spring cotters, loosen the special tool until the spring is fully released. Then, remove the tool.

WARNING

The reduction driven gear will pop out when the tool is removed without releasing the spring.

Remove the dowel pins.

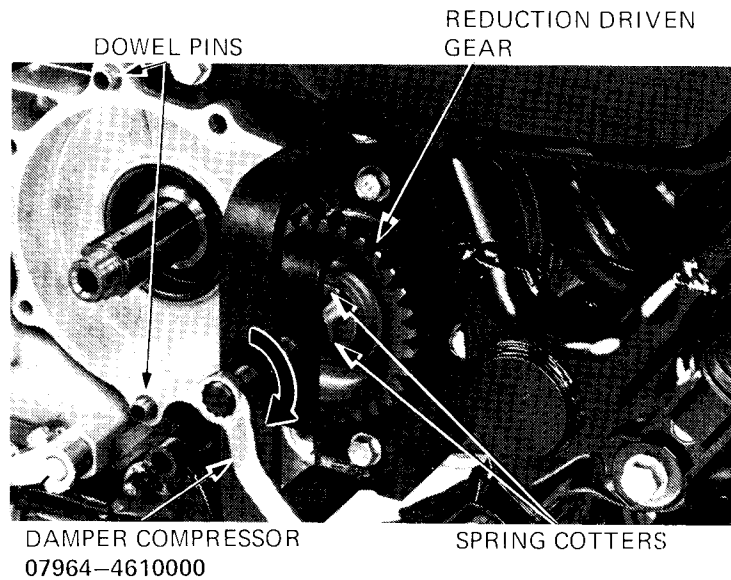

Remove the reduction driven gear, damper lifter, damper spring, damper spring seat.

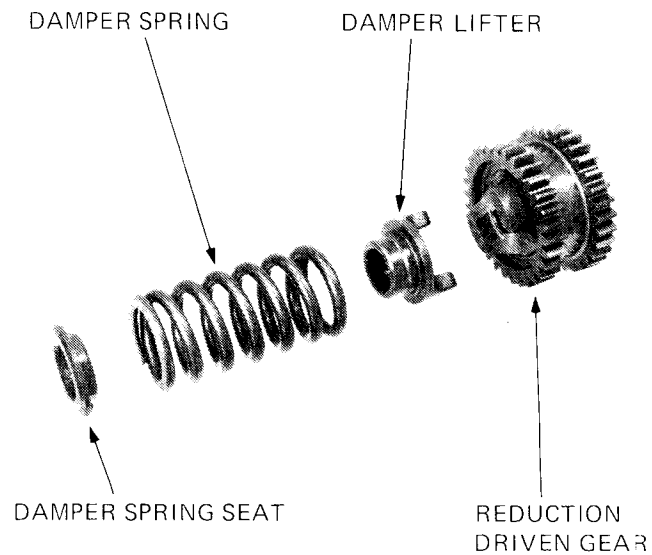

INSPECTION

Check drive gear slots, teeth and rubber for excessive or abnormal wear, or evidence of insufficient lubrication.

Measure each gear I.D. and collar O.D.

SERVICE LIMIT:

DRIVE GEAR (43T, 47T) I.D.:

31.04 mm (1.222 in)

GEAR COLLAR O.D.:

30.94 mm (1.218 in)

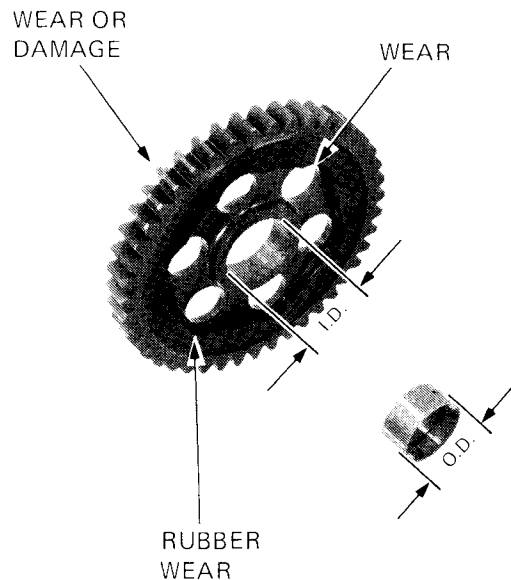



Check the driven gear teeth for excessive or abnormal wear, or evidence of insufficient lubrication.

Check the damper lifter for wear or damage.

Measure the driven gear I.D.

SERVICE LIMIT: 25.04 mm (0.982 in)

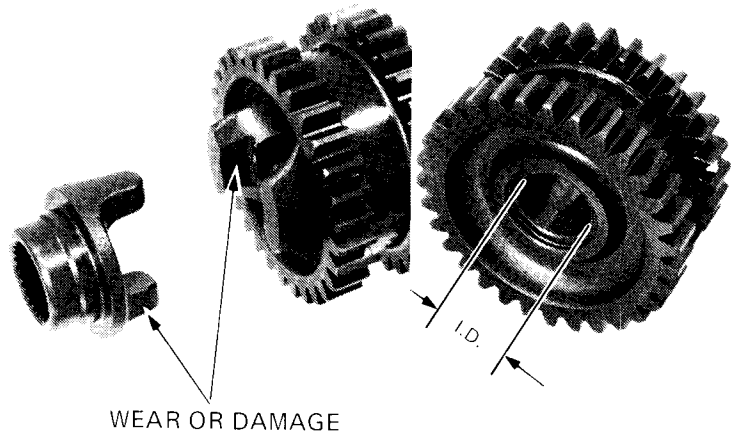

Measure the final drive gear shaft O.D.

SERVICE LIMIT: 24.95 mm (0.982 in)

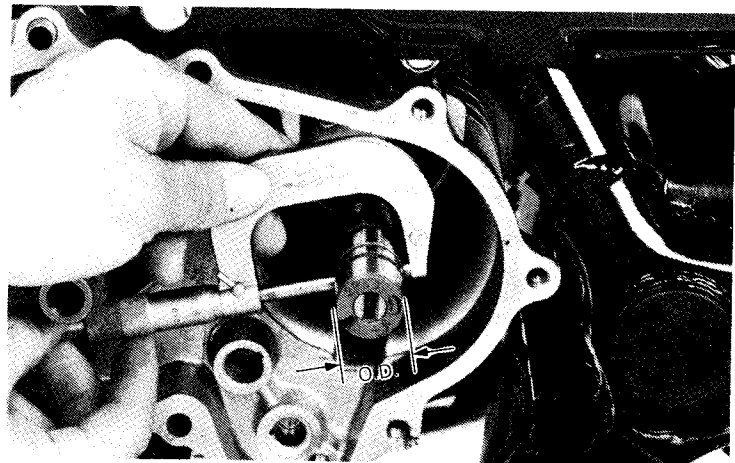

Inspect the shift drum end for scoring, scratches, or evidence of insufficient lubrication.

Check the shift drum grooves for damage.

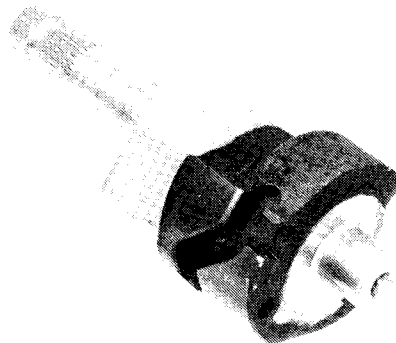



Measure the shift fork claw thickness.
SERVICE LIMIT: 5.7 mm (0.224 in)

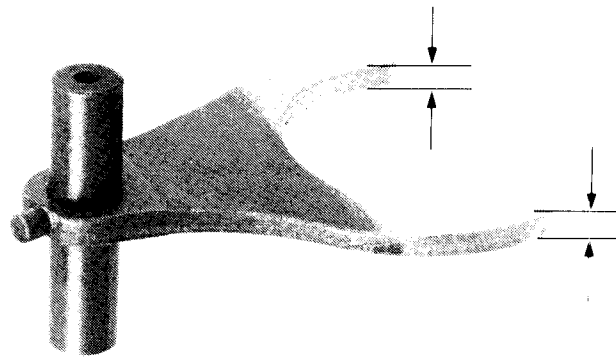

SUBTRANSMISSION ASSEMBLY

Install the damper spring seat, damper spring and damper lifter.

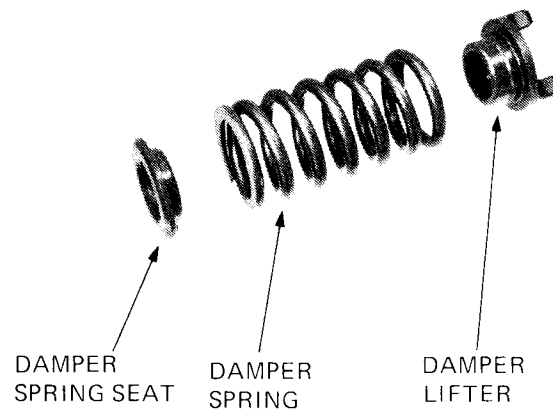

Install the reduction driven gear, and compress it with the special tool.
Install the spring cotters.
Remove the special tool.
Install the dowel pins.

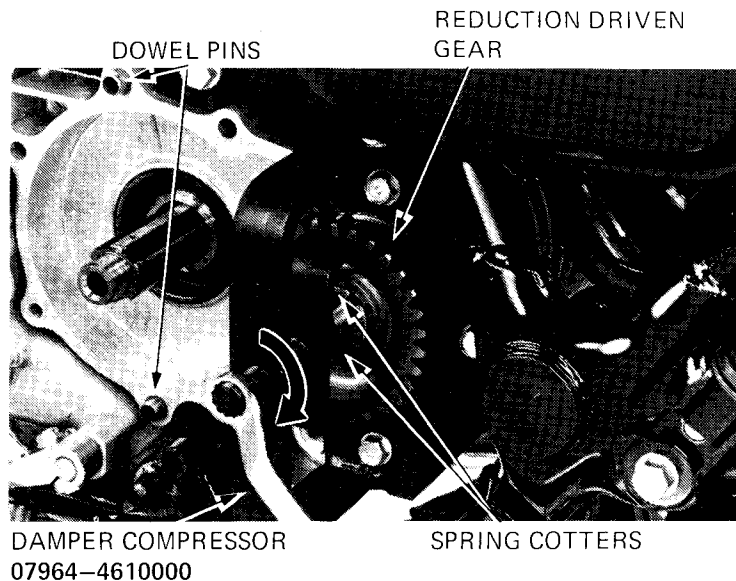



Install the splined washer onto the countershaft.

Install a reduction drive gear collar, aligning the collar's and the countershaft's oil holes.

Install the 47T reduction drive gear with the "OUT" mark facing toward you.

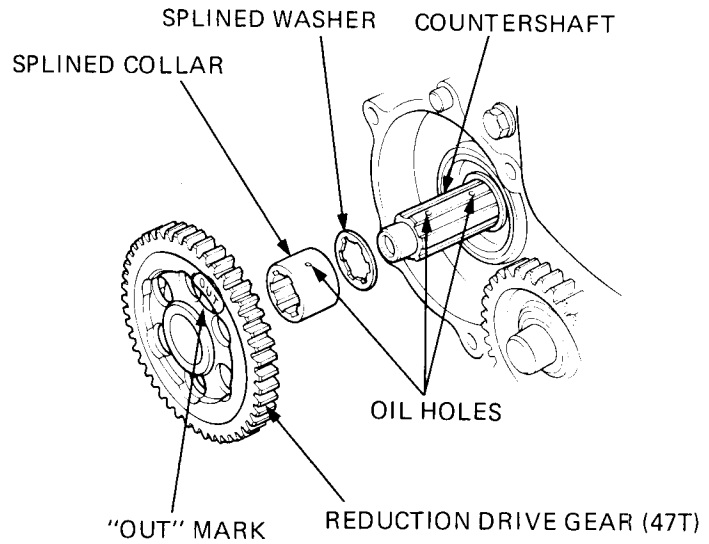

Install the splined collar.

Install the shifter and shift fork as an assembly. Engage the shifter dogs with the drive gear.

Install the other drive gear collar, aligning the collar's and the countershaft's oil holes.

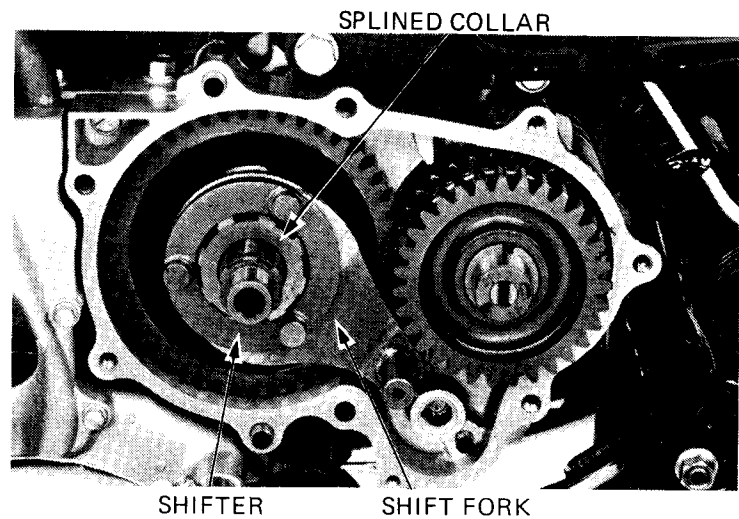

Install the 43T reduction drive gear with the "OUT" mark facing toward you.

Seat the cotters into the driveshaft grooves.

Place the thrust washer over the cotters.

Seat the cotter circlip into the cotter groove.

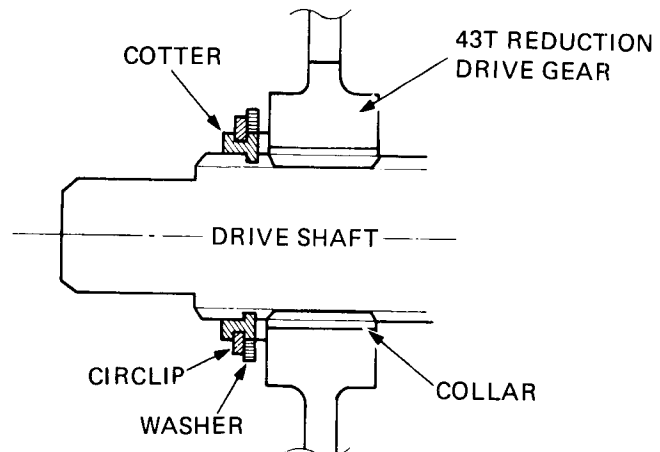



Install the stopper arm and spring.
Install the shift drum as shown.

NOTE

The shift drum groove will engage the shift fork boss automatically when the shift drum is assembled as shown.

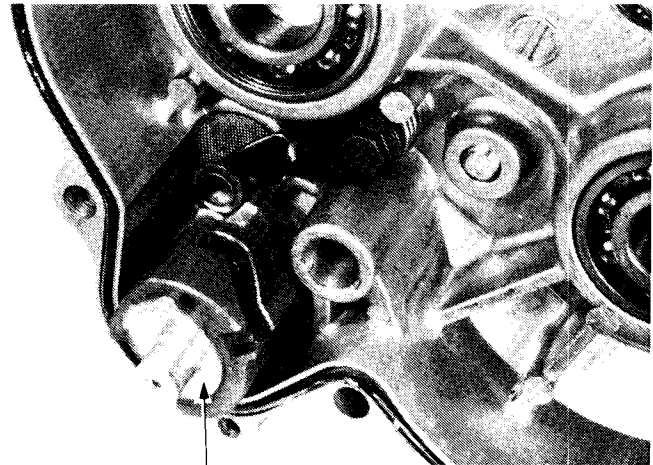

SHIFT DRUM

Install the cover.

NOTE

- Check the location of the shift drum or shift fork if difficulty is encountered in installing the cover.
- Do not strike the cover with excessive force.

Tighten the cover bolts.

TORQUE: 3.0–3.4 kg-m (22–25 ft-lb).

Install the exhaust pipe heat shield.

Fill the case with the recommended oil (page 2-9).

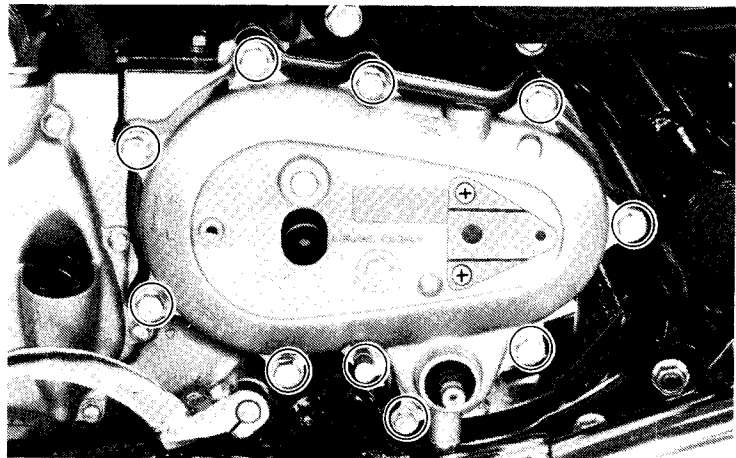

Align the punch marks and install the select arm.

Install the select pedal.

NOTE

Make sure that the select pedal toe end is in the "HI" position on the cover.

Install the foot pegs.

SELECT ARM

SELECT PEDAL

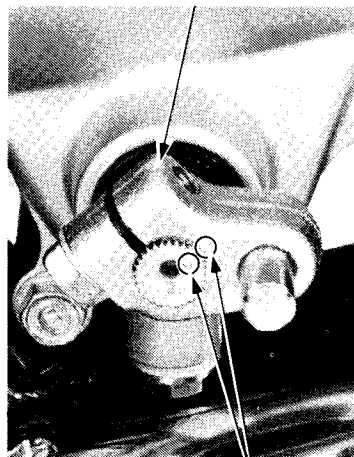

PUNCH MARKS



FOOT PEG



SUBTRANSMISSION CASE REMOVAL

- Remove the subtransmission (page 10-3).
- Remove the swing arm (page 15-12).
- Remove the foot pegs.
- Remove the right exhaust pipe heat shield.
- Remove the rear brake pedal.
- Remove the brake pedal bracket, and master cylinder bolts.

MASTER CYLINDER
SETTING BOLTS

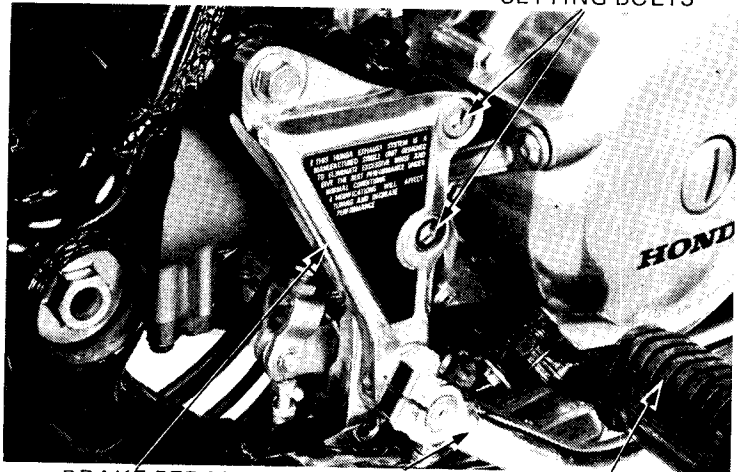

BRAKE PEDAL
BRACKET

BRAKE
PEDAL

FOOT PEGS

Remove the subtransmission case mounting bolts.

Remove the subtransmission case.

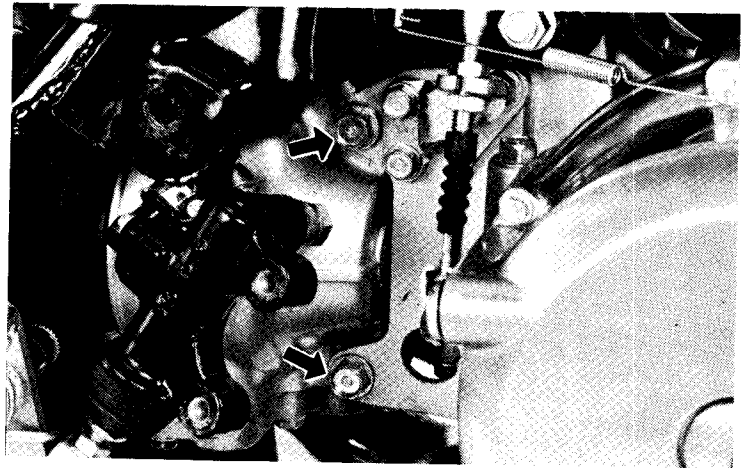

RETAINER B OIL SEAL REPLACEMENT

DRIVE GEAR REMOVAL

Attach the subtransmission case to the base.

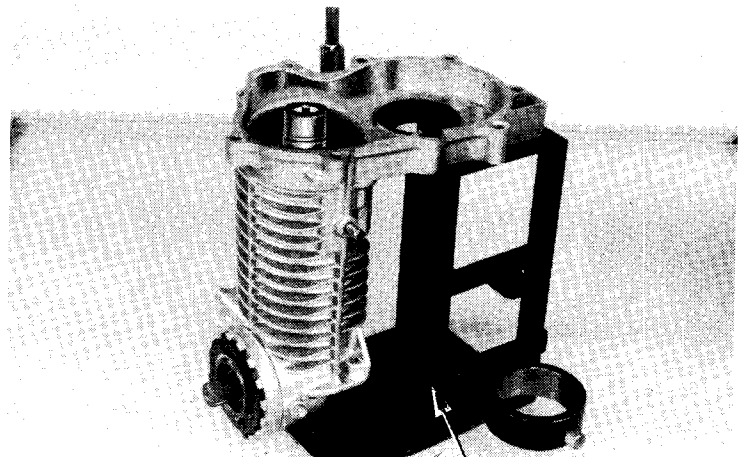

SUBTRANSMISSION BASE
07965-461000 (Not available in U.S.A.)



Remove the baffle plate.
Straighten the lock washer tab.

Remove the lock nut.

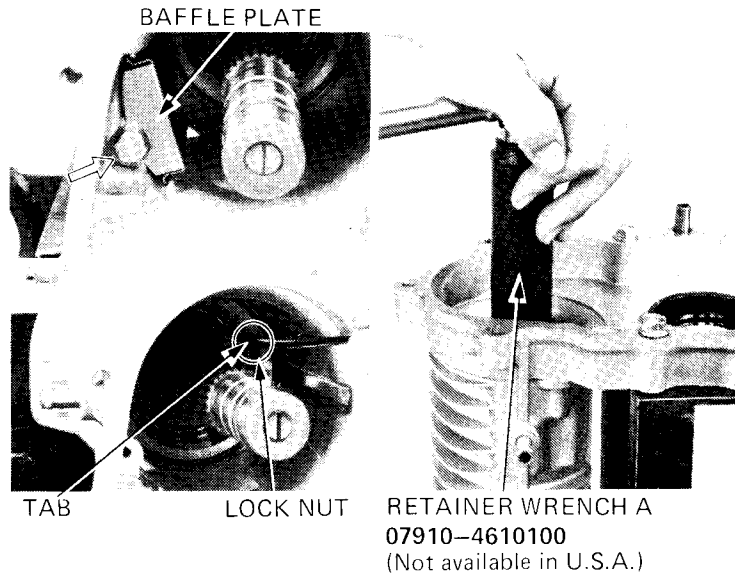

Remove the lock washer, spring washer and drive gear assembly with the drive gear shim.

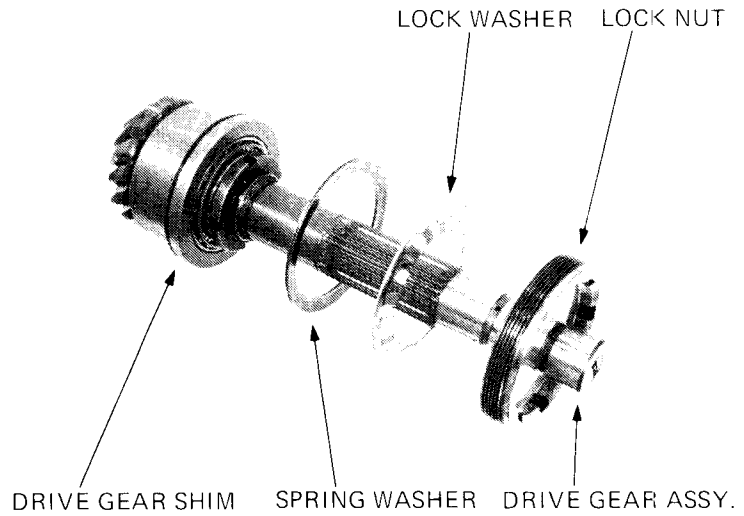

RETAINER B AND DRIVEN GEAR ASSEMBLY REMOVAL

Remove the circlip and lock washer.
Remove the retainer positioning bolt.
Remove the lock nut.

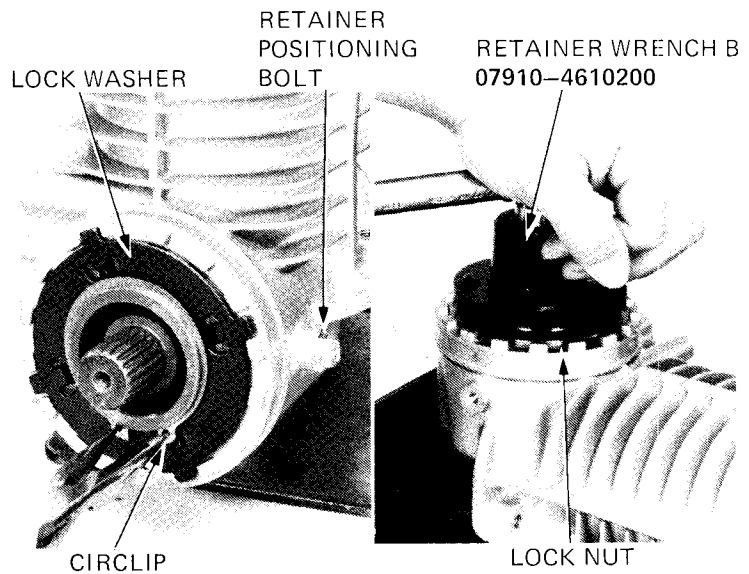



Heat the outside of the case evenly with a 1 kw dryer for more than 15 minutes.

Hold the dryer about 5 cm (2 in) from the case.

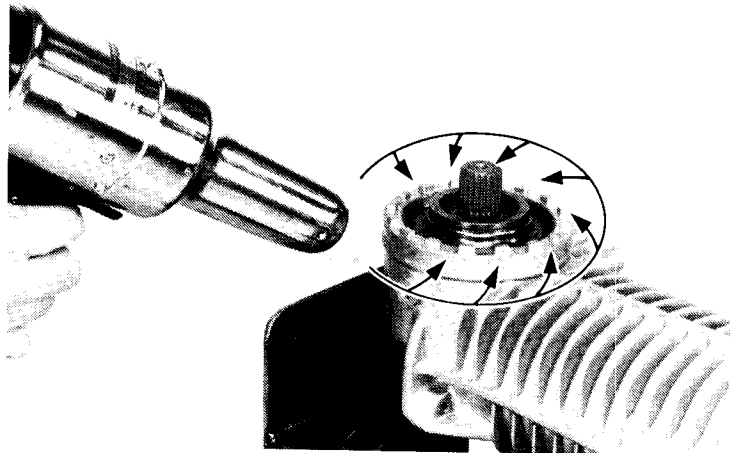

Remove retainer B and driven gear assembly, tapping around the case with a plastic hammer.

NOTE

Check that the 30203C bearing outer is removed with the gear assembly.

WARNING

Be sure to wear gloves when removing the heated case.

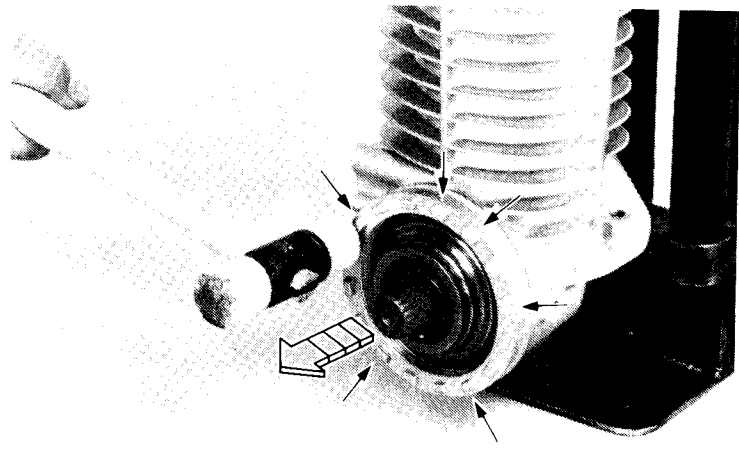

RETAINER B OIL SEAL AND O-RING REPLACEMENT

Drive out the oil seal.
Remove the retainer B o-ring.

NOTE

Replace the O-ring with a new one whenever retainer B is disassembled.

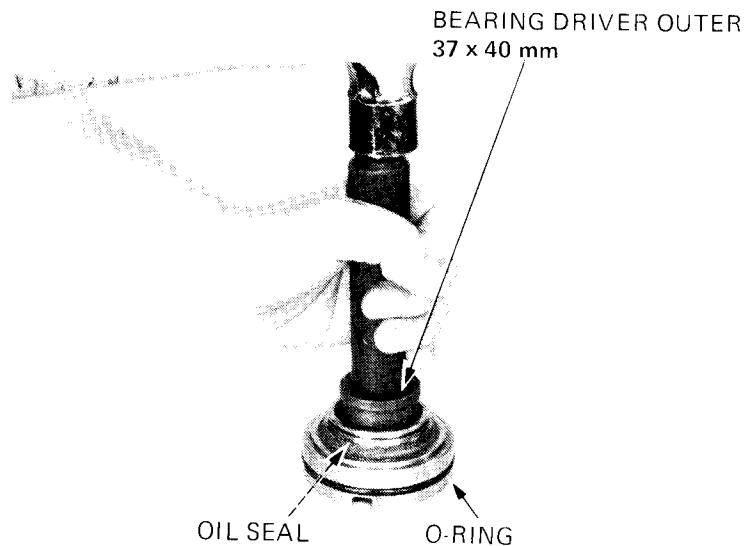

Install a new O-ring on **retainer B**.
Coat the new oil seal with gear oil.
Drive the oil seal into retainer B.

NOTE

- Install the oil seal with the sealing lip facing the inside.
- Avoid damaging the oil seal spring band.
- Before driving in the oil seal check that the 20306C bearing is in place in retainer B.

RETAINER B AND DRIVEN GEAR INSTALLATION

Place retainer B over the driven shaft, aligning the groove with the retainer positioning bolt hole and drive it into the case until the 20306C bearing outer race lightly seats on the inner bearing.

CAUTION:

- *Drive retainer B in squarely.*
- *Rotate the driven shaft while driving retainer B. Stop driving when resistance is felt.*

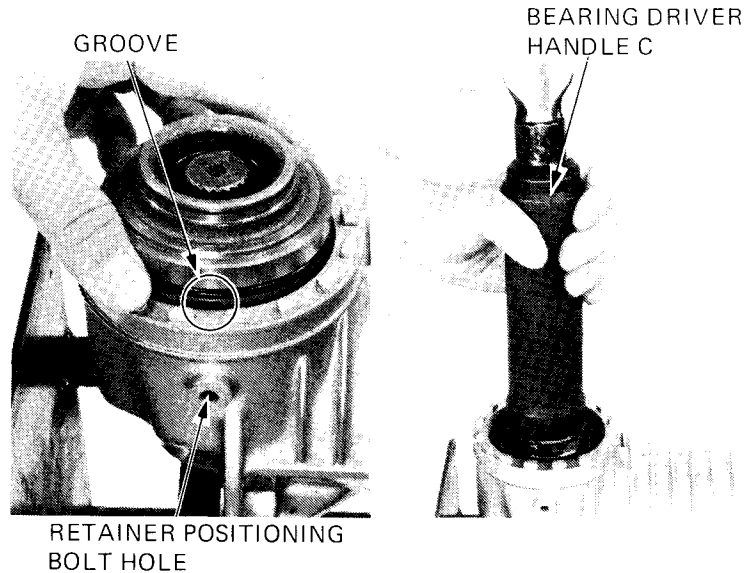
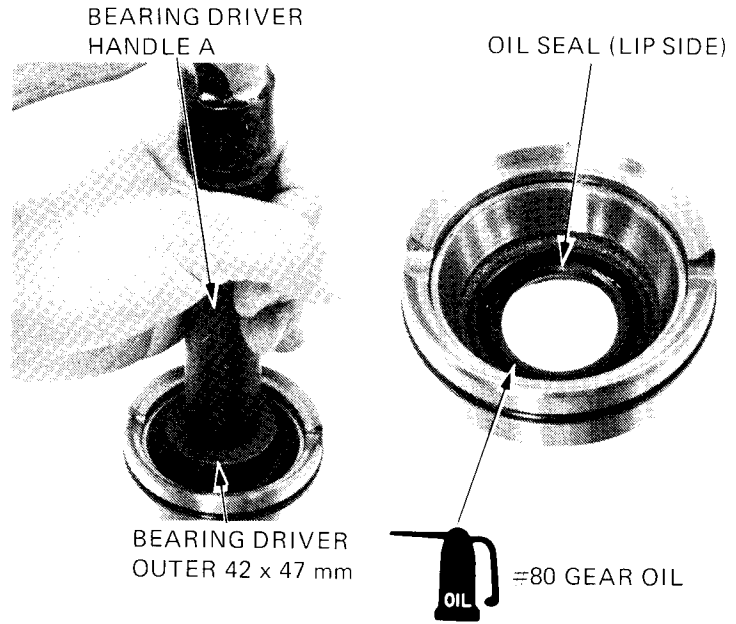

Install the special tool.
Install and tighten the lock nut.

TORQUE: 3.5–4.5 kg-m (25–33 ft-lb)

Rotate the driven gear shaft 2–3 turns.

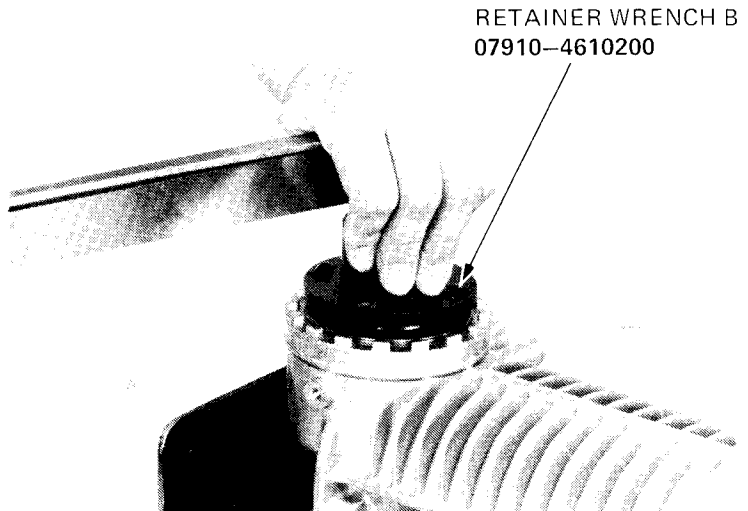



Slide the PRELOAD INSPECTION TOOL over the shaft through a spacer. Secure with the lock screw.

NOTE

Before tightening, make sure that the end of the lock screw is inserted in the shaft splines.

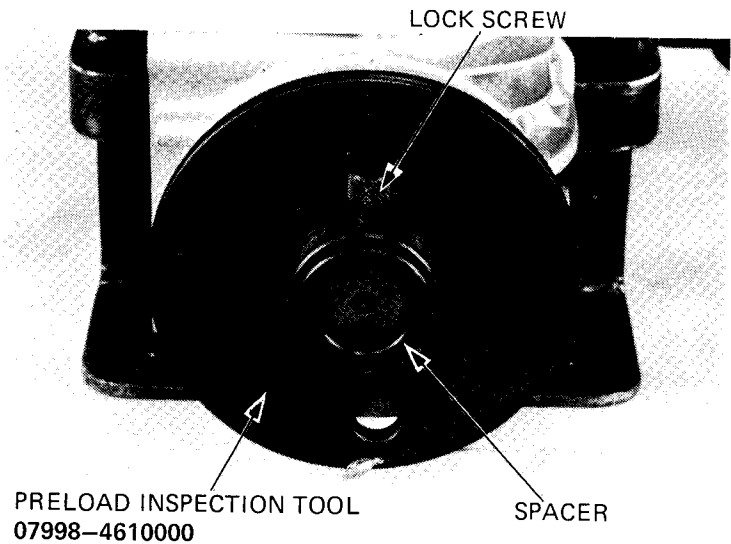

DRIVEN GEAR PRELOAD INSPECTION

Wind the string around the groove of the tool. Attach a spring scale to the string and measure the force needed to turn the tool.

NOTE

Force required to begin gear movement may exceed preload limits.

DRIVEN GEAR PRELOAD: 0.6–0.8 kg (1.32–1.76 lbs)
[3.0–4.0 kg-cm, 2.6–3.5 in-lb]

To increase the preload, turn in the lock nut.

NOTE

Turn the shaft 2–3 rotations each time the nut is tightened.

Recheck the preload.

Install and tighten the retainer positioning bolt.

Install the lock washer and circlip.

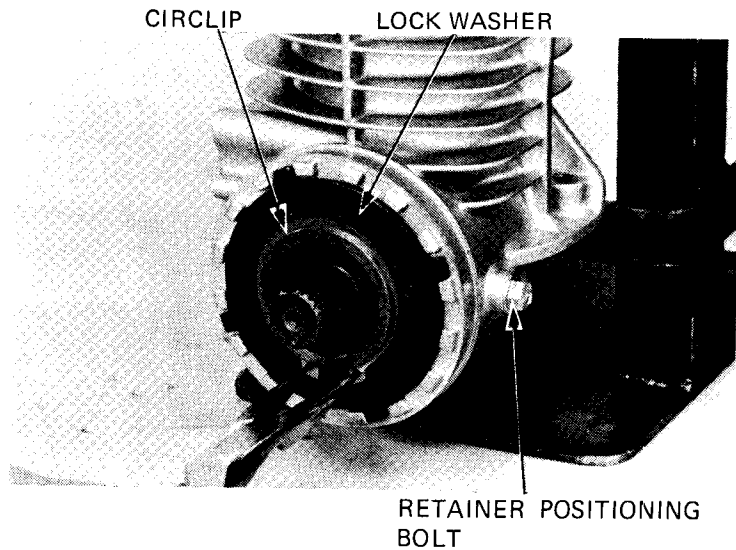
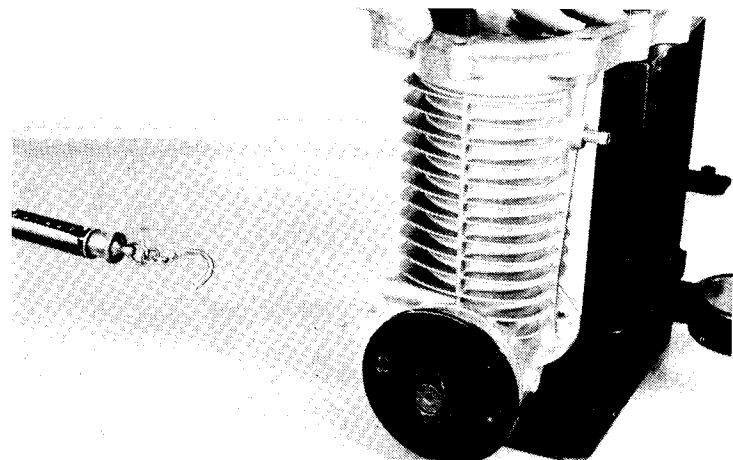



DRIVE GEAR INSTALLATION

Install the drive gear assembly with shim into the final gear case.
Install the spring washer.

NOTE

Be sure the washer facing direction marked "OUT" is correct.

Install the lock washer aligning the lock washer tang with the case groove.

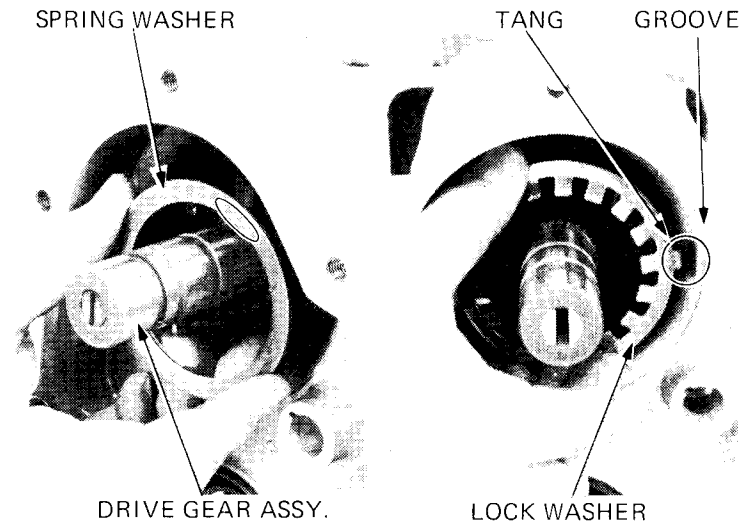

Install and tighten the lock nut.

TORQUE: 9.5–10.5 kg-m (69–76 ft-lb).

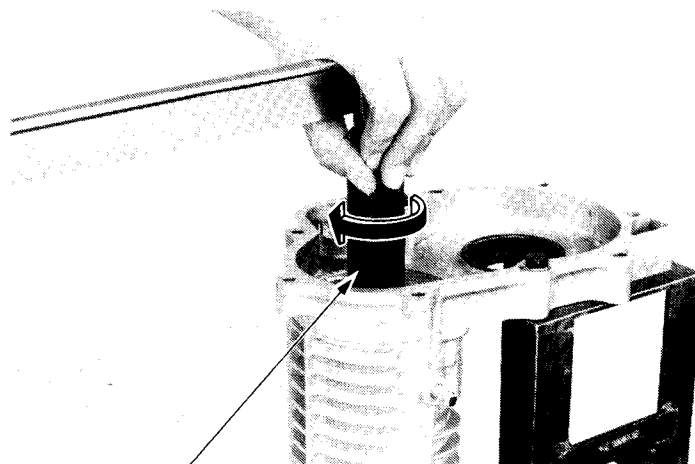

RETAINER WRENCH A
07910-4610100 (Not available in U.S.A.)

Bend the tabs of the lock washer.
Install the baffle plate.
Coat the bolt threads and underside of the bolt with thread lock and tighten.
Remove the final drive case from the base.

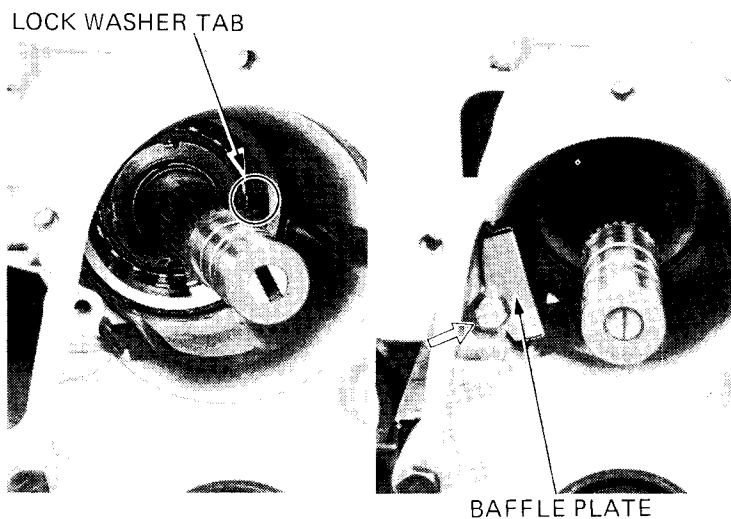



SUBTRANSMISSION CASE INSTALLATION

Attach the subtransmission case to the engine.
Install the subtransmission (page 10-6).
Tighten the subtransmission case mounting bolts.

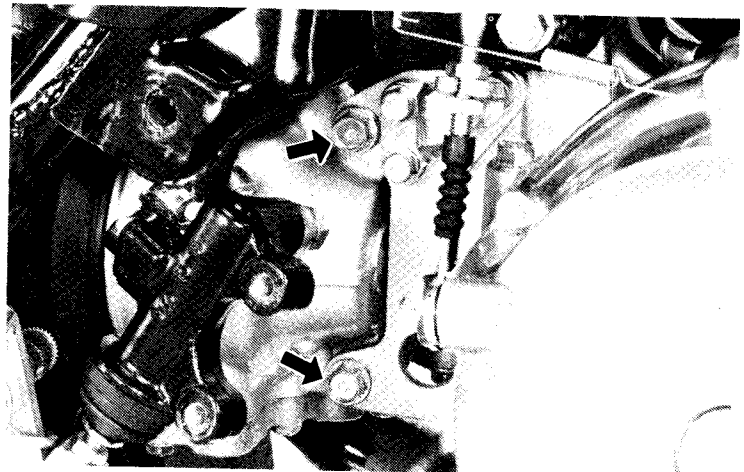

Install the master cylinder holder bolts, then the master cylinder mounting bolts.
Install the brake pedal and right exhaust pipe heat shield.

Install the foot pegs.
Install the swing arm (page 15-15).

Fill the subtransmission with the recommended oil (page 2-9).

OIL CAPACITY: 0.6 liter
(0.61 U.S. qt.)

OIL TYPE: Hypoid Gear Oil
API, GL-5
SAE #80

MASTER CYLINDER HOLDER BOLTS

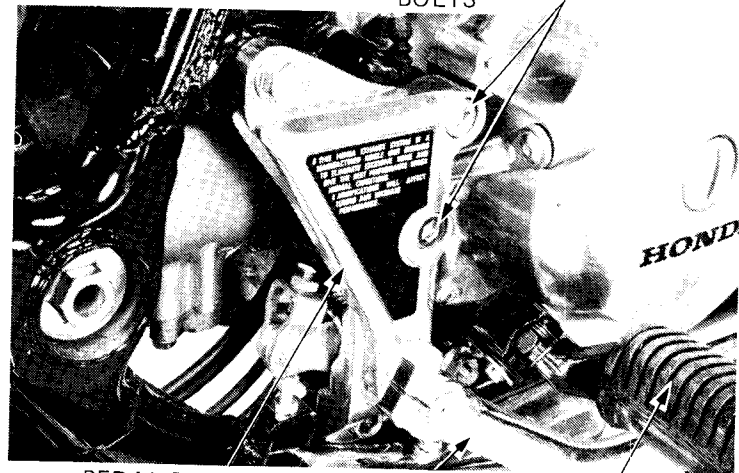

PEDAL BRACKET

BRAKE PEDAL

FOOT PEGS