



HOW TO USE THIS MANUAL

Follow the Maintenance Schedule recommendations to ensure that the vehicle is in peak operating condition and the emission levels are within the standards set by the U.S. Environmental Protection Agency. Performing the first scheduled maintenance is very important. It compensates for the initial wear that occurs during the break-in period.

Sections 1 through 3 apply to the whole motorcycle, while sections 4 through 21 describe parts of the motorcycle, grouped according to location.

Find the section you want on this page, then turn to the table of contents on page 1 of that section.

Most sections start with an assembly or system illustration, service information and troubleshooting for the section. The subsequent pages give detailed procedures.

If you are not familiar with this motorcycle, read the TECHNICAL FEATURES in section 22.

If you don't know the source of the trouble, go to section 23, TROUBLESHOOTING.

Service information for 1981 and later models is in the Addendums beginning with Section 24.

ALL INFORMATION, ILLUSTRATIONS, DIRECTIONS AND SPECIFICATIONS INCLUDED IN THIS PUBLICATION ARE BASED ON THE LATEST PRODUCT INFORMATION AVAILABLE AT THE TIME OF APPROVAL FOR PRINTING. HONDA MOTOR CO., LTD. RESERVES THE RIGHT TO MAKE CHANGES AT ANY TIME WITHOUT NOTICE AND WITHOUT INCURRING ANY OBLIGATION WHATEVER.

NO PART OF THIS PUBLICATION MAY BE REPRODUCED WITHOUT WRITTEN PERMISSION.

HONDA MOTOR CO., LTD.
SERVICE PUBLICATIONS OFFICE

	GENERAL INFORMATION	1
	LUBRICATION	2
	INSPECTION AND ADJUSTMENT	3
ENGINE	FUEL SYSTEM	4
	ENGINE REMOVAL/INSTALLATION	5
	CYLINDER HEAD/VALVE	6
	CYLINDER/PISTON	7
	CLUTCH	8
	GEARSHIFT LINKAGE	9
	SUBTRANSMISSION	10
	CRANKCASE	11
	TRANSMISSION	12
	CRANKSHAFT/PRIMARY SHAFT	13
CHASSIS	FRONT WHEEL/SUSPENSION	14
	REAR WHEEL/SUSPENSION	15
	FINAL DRIVE	16
	HYDRAULIC BRAKE	17
ELECTRICAL	BATTERY/CHARGING SYSTEM	18
	IGNITION SYSTEM	19
	ELECTRIC STARTER	20
	SWITCHES	21
	TECHNICAL FEATURES	22
	TROUBLESHOOTING	23
	'81 CB900C ADDENDUM	24
	'81 CB900F ADDENDUM	25
	'82 CB900C • F ADDENDUM	26



MODEL IDENTIFICATION

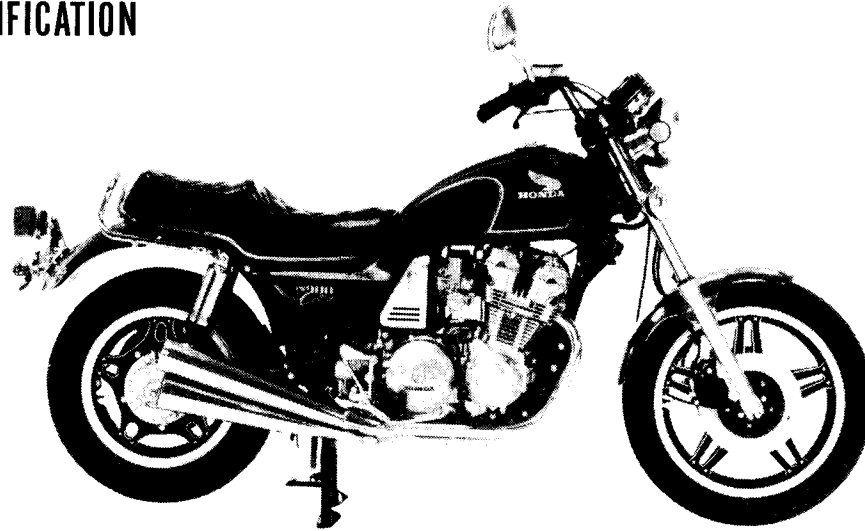

BEGINNING WITH F No. SC04-2000046
F No. SC04-2001669 [CANADA model]

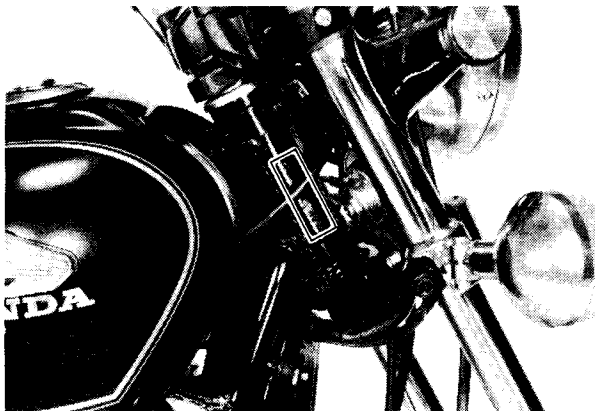

The frame serial number is stamped on the steering head right side.

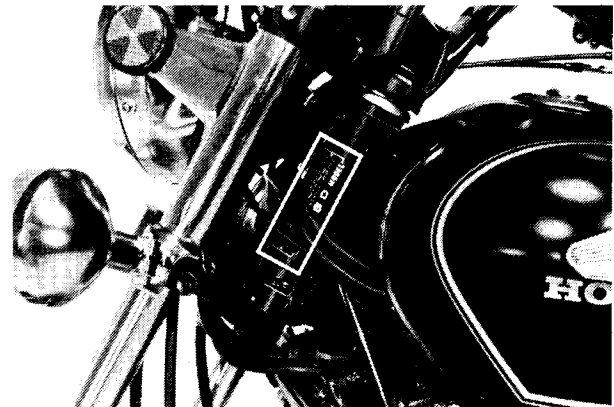

The vehicle identification number (VIN) is on the steering head left side.

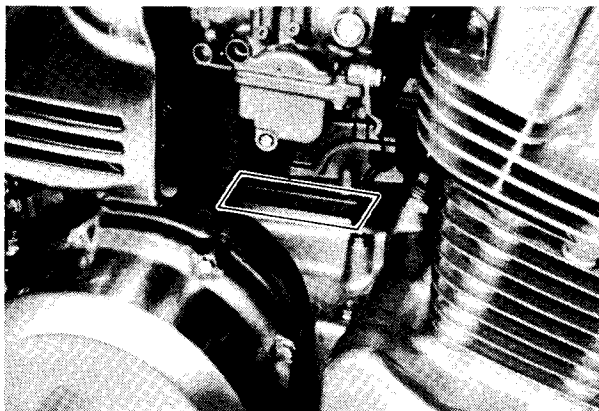

The engine serial number is stamped on top of the right crankcase.

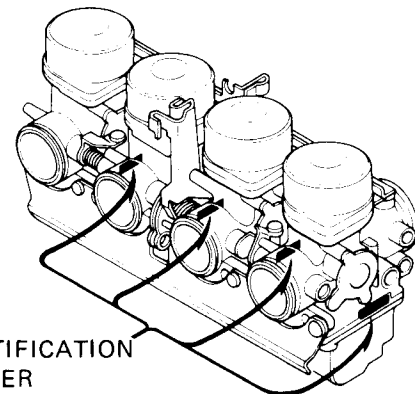

IDENTIFICATION
NUMBER

The carburetor identification number is on the carburetor body left side.



GENERAL SAFETY	1-1	CABLE & HARNESS ROUTING	1-9
SERVICE RULES	1-1	MAINTENANCE SCHEDULE	1-11
SPECIFICATIONS	1-2	EMISSION CONTROL SYSTEM	1-12
TORQUE VALUES	1-4	EMISSION CONTROL INFORMATION LABEL	1-12
SPECIAL TOOLS/COMMON TOOLS	1-7		

GENERAL SAFETY

WARNING

If the engine must be running to do some work, make sure the area is well-ventilated. Never run the engine in a closed area. The exhaust contains poisonous carbon monoxide gas.

WARNING

Gasoline is extremely flammable and is explosive under certain conditions. Do not smoke or allow flames or sparks in your working area.

WARNING

The battery electrolyte contains sulfuric acid. Protect your eyes, skin and clothing. In case of contact, flush thoroughly with water and call a doctor if your eyes were exposed.

WARNING

The battery generates hydrogen gas which can be highly explosive. Do not smoke or allow flames or sparks near the battery, especially while charging it.

SERVICE RULES

1. Use genuine HONDA or HONDA-recommended parts and lubricants or their equivalent. Parts that do not meet HONDA's design specifications may damage the motorcycle.
2. Use the special tools designed for this product.
3. Use only metric tools when servicing this motorcycle. Metric bolts, nuts, and screws are not interchangeable with English fasteners. The use of incorrect tools and fasteners may damage the motorcycle.
4. Install new gaskets, O-rings, cotter pins, lock plates, etc. when reassembling.
5. When tightening bolts or nuts, begin with larger-diameter or inner bolts first, and tighten to the specified torque diagonally, unless a particular sequence is specified.
6. Clean parts in cleaning solvent upon disassembly. Lubricate any sliding surfaces before reassembly.
7. After reassembly, check all parts for proper installation and operation.

**SPECIFICATIONS**

★ When a genuine Honda fairing is installed.

ITEM			
DIMENSIONS	Overall length	2,310 mm (90.9 in)	
	Overall width	915 mm (36.0 in)	
	Overall height	1,170 mm (46.1 in)	
	Wheelbase	1,580 mm (62.2 in)	
	Seat height	780 mm (30.7 in)	
	Foot peg height	330 mm (13.0 in)	
	Ground clearance	150 mm (5.9 in)	
	Dry weight	259 kg (571 lb)	
Curb weight	277 kg (611 lb)		
FRAME	Type	Double cradle	
	Front suspension, travel	Telescopic fork 160 mm (6.3 in)	
	Rear suspension, travel	Swing arm/Shock absorber, 101 mm (4.0 in)	
	Gross vehicle weight rating	485 kg (1,070 lb)	
	Vehicle capacity load	208 kg (460 lb)	
	Front tire size	110/90-19-62H Universal pattern	
	Rear tire size	130/90-16-67H Universal pattern	
	Cold tire pressures	Up to 90 kg (200 lbs) load	Front 2.25 kg/cm ² (32 psi) ★ 2.8 (40 psi) Rear 2.25 kg/cm ² (32 psi)
		Up to vehicle capacity load	Front 2.25 kg/cm ² (32 psi) ★ 2.8 (40 psi) Rear 2.8 kg/cm ² (40 psi)
	Front brake, lining swept area	Double disc brake 1200 cm ² (186.0 sq in)	
Rear brake, lining swept area	Single disc brake 653 cm ² (101.2 sq in)		
Fuel capacity	16.5 liters (4.4 US gal, 3.6 Imp gal)		
Fuel reserve capacity	4.5 liters (1.2 US gal, 1.0 Imp gal)		
Caster angle	29°		
Trail	124 mm (4.9 in)		
Front fork oil capacity	280 ± 2.5 cc (9.5 ± 0.008 ozs)		
ENGINE	Type	Air cooled 4-stroke	
	Cylinder arrangement	Vertical in-line four	
	Bore and stroke	64.5 x 69.0 mm (2.54 x 2.72 in)	
	Displacement	902 cm ³ (55.0 cu in)	
	Compression ratio	8.8 : 1	
	Valve train	Chain driven DOHC 4 Valves per cylinder	
	Maximum horsepower	84 BHP/8,500 rpm	
	Maximum torque	7.8 kg-m (56.4 ft-lb)/7,000 rpm	
	Oil capacity	4.5 liters (4.8 US qt, 4.0 Imp qt) after disassembly	
		3.5 liters (3.7 US qt, 3.0 Imp qt) after draining	
	Lubrication system	Wet sump	
	Air filtration	Paper	
	Cylinder compression	12.0 ± 2.0 kg/cm ² (170 ± 28 psi)	
	Intake valve	Opens	10° (BTDC) at 1 mm lift, 63° (BTDC) at 0 lift
		Closes	35° (ABDC) at 1 mm lift, 98° (ABDC) at 0 lift
	Exhaust valve	Opens	40° (BBDC) at 1 mm lift, 70° (BBDC) at 0 lift
		Closes	5° (ATDC) at 1 mm lift, 93° (ATDC) at 0 lift
	Valve clearance (Cold)	IN:	} 0.06–0.13 mm (0.002–0.005 in)
		EX:	
	Engine weight	106 kg (234 lb)	
Idle speed	1,000 ± 100 rpm		



[] CANADA model

ITEM					
CARBURETION	Carburetor type	VB, 32 mm (1.26 in) venturi bore			
	Identification number	VB43A [VB43B]			
	Pilot screw initial setting	See page 4-17			
	Float level	15.5 mm (0.61 in)			
DRIVE TRAIN	Clutch	Wet, multi-plate			
	Transmission	5-speed constant-mesh with dual range subtransmission			
	Primary reduction	1.000 (28/28)/2.041 (49/24)			
	Final reduction	3.091 (34/11)			
	Secondary reduction (subtransmission)	I (High range)	0.638 (30/47)		
		II (Low range)	0.721 (31/43)		
	Third reduction	1.200 (18/15)			
	Gear ratio I	2.375 (38/16)			
	Gear ratio II	1.789 (34/19)			
	Gear ratio III	1.391 (32/23)			
	Gear ratio IV	1.160 (29/25)			
	Gear ratio V	0.964 (27/28)			
	Gear shift pattern	Left foot operated return system, 1-N-2-3-4-5			
	Subtransmission gear oil capacity	0.60 liters (0.61 US qt, 0.53 Imp qt)			
Final drive gear oil capacity	0.15 liters (0.16 US qt, 0.13 Imp qt)				
ELECTRICAL	Ignition	Transistorized			
	Ignition timing "F-I" mark	10° BTDC at idle			
	Full advance	38.5° BTDC at 3,200 rpm			
	Starting system	Starting motor			
	Generator	Three phase A.C. generator 266 W/5,000 rpm			
	Battery capacity	12 V-14 AH			
	Spark plug	(): Canada model			
		For cold climate below 5°C (41°F)		Standard	
		NGK	ND	NGK	ND
		D8EA [DR8ES-L]	X24ES-U [X24ESR-U]	D9EA [DR8ES]	X27ES-U [X27ESR-U]
Spark plug gap	0.6-0.7 mm (0.024-0.028 in)				
Firing order	1-2-4-3				
Fuse/Main fuse	10 A/30 A				
LIGHTS	Headlight (high/low beam)	60/55 W H4 BULB (Phillips 12342/99 or equivalent)			
	Tail/stoplight	8/27 W	3/32 cp	SAE NO. 1157	
	Front turn signal/running light	23/8 W	32/3 cp	SAE NO. 1034	
	Rear turn signal	23 W	32 cp	SAE NO. 1073	
	Speedometer light	3.4 W	2 cp	SAE NO. 57	
	Tachometer light	3.4 W	2 cp	SAE NO. 57	
	Neutral indicator	3.4 W	2 cp	SAE NO. 57	
	Turn signal indicator	3.4 W	2 cp	SAE NO. 57	
	High beam indicator	3.4 W	2 cp	SAE NO. 57	
	Rear suspension air pressure warning light	3.4 W	2 cp	SAE NO. 57	



TORQUE VALUES

• ENGINE

Item	Q'ty	Thread Dia (mm)	Torque kg-m (ft-lb)	Remarks
Cylinder head cover	8	6	0.8- 1.2 (6- 9)	Apply molybdenum di-sulfide grease to threads and underside of nuts
Cam holder	24	6	1.2- 1.6 (9-12)	
Cylinder head	12	10	3.6- 4.0 (26-29)	
Cam sprocket	4	7	2.2- 2.6 (16-19)	
Spark plug	4		1.2- 1.9 (9-14)	Apply molybdenum di-sulfide grease to threads and underside of nuts
Crankcase		8	2.1- 2.5 (15-18)	
A.C. generator	1	12	8.0-10.0 (58-72)	
Primary shaft	1	12	8.0-10.0 (58-72)	
Main shaft	1	16	3.8- 4.2 (28-30)	
Connecting rod nut	8		3.2 (23)	
Oil Filter center bolt	1		2.8- 3.2 (20-23)	Apply liquid sealant
Oil pressure switch	1		1.5- 2.0 (11-14)	
Neutral switch	1		1.6- 2.0 (12-14)	
Oil drain plug	1	14	3.5- 4.0 (25-29)	
Oil pipe	2	10	2.1- 2.5 (15-18)	
Spark advancer	1	8	3.3- 3.7 (24-27)	Apply LOCTITE® 271 to the threads
Starting clutch	3	8	2.6- 3.0 (19-22)	
Subtransmission	9	8	3.0- 3.4 (22-25)	
Oil level check bolt	1	12	2.0- 2.5 (14-18)	NEW
Oil drain bolt	1	8	1.6- 2.0 (12-14)	NEW

• CHASSIS

Item	Q'ty	Thread Dia (mm)	Torque kg-m (ft-lb)	Remarks
Steering stem nut	1	24	8.0-12.0 (58-87)	Apply oil to threads and tighten to 2.0 (14) when installing a genuine Honda fairing.
Steering top thread	1	26	1.4- 1.6 (10-12)	
Handlebar holder	4	8	1.8- 2.5 (13-18)	
Front fork top bridge	2	7	0.9- 1.3 (7- 9)	
Front fork bolt	2	31	1.5- 3.0 (11-22)	
Steering stem	2	10	4.5- 5.5 (33-40)	
Front axle holder	4	10	3.0- 4.0 (22-29)	
Front axle nut	1	12	5.5- 6.5 (40-47)	
Front fork socket bolt	2	8	1.5- 2.5 (11-18)	
Front fork drain bolt	2	6	0.6- 0.9 (4.3-7)	
Front fork hose joint (R)	1	10	1.5- 2.0 (11-14)	
Front fork hose joint (L)	1	8	0.4- 0.7 (2.9-5.1)	



Item	Q'ty	Thread Dia (mm)	Torque kg-m (ft-lb)	Remarks
Front fork hose connector	1	8	0.4- 0.7 (2.9-5.1)	UBS
Front fork air valve	1	8	0.4- 0.7 (2.9-5.1)	
Front/rear brake disc	5	8	2.7- 3.3 (20-24)	
Brake caliper carrier	2	10	3.0- 4.0 (22-29)	
Rear axle nut	1	18	8.0-10.0 (58-72)	
Rear axle holding bolt	1	8	2.4- 2.9 (17-21)	
Rear brake pedal holder	2	10	3.5- 4.5 (25-33)	
Rear brake pedal	1	8	1.8- 2.5 (13-18)	
Rear brake torque link	1	8	1.9- 2.3 (14-17)	
Rear shock absorber	3	10	3.0- 4.0 (22-29)	
Rear shock absorber pin bolt	1	14	4.0- 5.0 (29-36)	
Engine hanger bolt	5	10	3.5- 4.5 (25-33)	
Rear shock absorber rod lock nut	2	11	3.5- 6.0 (25-43)	
Rear shock absorber air valve (3-way joint)	1	8	0.4- 0.7 (2.9-5.1)	
Rear shock absorber hose connector (3-way joint)	2	8	0.8- 1.2 (5.8-9)	
Rear shock absorber hose joint	2	8	0.4- 0.7 (2.9-5.1)	
Rear shock absorber hose joint (3-way)	2	10	1.5- 2.0 (11-14)	
Rear shock absorber air sensor	1	10	0.8- 1.2 (5.8-9)	
3-Way joint	1	14	1.9- 2.3 (14-17)	
Swing arm pivot bolt				
(Right)	1	35	5.0- 7.0 (36-51)	
(Left)	1	35	1.6- 2.0 (12-14)	
Swing arm pivot nut	1	35	5.0- 7.0 (36-51)	
Final gear case	3	10	3.5- 4.5 (25-33)	
Final gear case cover	2	10	3.5- 4.5 (25-33)	
	6	8	2.3- 2.8 (17-20)	
Final gear case drain bolt	1	6	1.0- 1.4 (7-10)	
Filler cap bolt	1	30	1.0- 1.4 (7-10)	
Pinion nut	1	16	4.0- 5.0 (29-36)	



Torque specifications listed above are for important fasteners. Others should be tightened to standard torque values below.

• STANDARD TORQUE VALUES

Item	Torque Values kg-m (ft-lb)	Item	Torque Values kg-m (ft-lb)
5 mm bolt and nut	0.4 -0.6 (3- 4)	5 mm screw	0.3 -0.5 (3- 4)
6 mm bolt and nut	0.8 -1.2 (6- 9)	6 mm screw	0.7 -1.1 (5- 8)
8 mm bolt and nut	1.8 -2.5 (13-18)	6 mm flange bolt and nut	1.0 -1.4 (7-10)
10 mm bolt and nut	3.0 -4.0 (22-29)	8 mm flange bolt and nut	2.0 -3.0 (14-22)
12 mm bolt and nut	5.0 -6.0 (36-43)	10 mm flange bolt and nut	3.0 -4.0 (22-29)



TOOLS

• SPECIAL TOOLS

Tool Name	Tool No.	Q'ty	Ref. page
Vacuum gauge set	07404-0020000	1	3-10
Oil pressure gauge	07506-3000000	1	2- 5
Oil pressure gauge attachment	07510-4220100	1	2- 4
Primary gear holder	07924-4250000	1	8- 5, 8- 6
Rotor puller	07933-4250000	1	18- 6
Bearing race remover	07953-4250001	1	15-24
Carburetor adjusting wrench	07908-4220100	1	3-11
Carburetor pilot screw wrench	07908-4220201	1	3-17
Snap ring pliers	07914-3230001	1	17- 8, 17-15
Steering stem socket	07916-3710100	1	14-25
6 mm hollow set wrench	07917-3230000	1	14-16, 14-19
Bearing race remover	07946-3710500	1	14-24
Steering stem driver	07946-3710600	1	14-23
Bearing driver attachment	07946-3710700	1	14-24
Piston base	07958-3000000	2	7- 8
Valve lifter holder	07964-4220001	1	3- 7
Valve guide reamer 5.5 mm	07984-2000000	1	6-14, 6-15
Piston ring compressor	07954-4220000	2	7- 8
Valve lifter bore protector	07999-4220000	1	6-11
Socket bit 10 mm	07917-3710000	1	8- 6
Clutch adjusting wrench	07908-3230000	1	3-18
Valve seat cutter 24.5 mm	07780-0010100	1	} 6-16
Valve seat cutter 27.5 mm	07780-0010200	1	
Valve seat flat cutter 28 mm	07780-0012100	1	
Valve seat flat cutter 30 mm	07780-0012200	1	
Valve seat interior cutter 30 mm	07780-0014000	1	
Valve seat cutter holder 5.5 mm	07781-0010100	1	
Retainer wrench A	07910-4610100	1	10- 9
Retainer wrench B	07910-4610200	1	10-10, 10-11, 10-14
Damper compressor	07964-4610000	1	10- 4, 10- 6
Preload inspection tool	07998-4610000	1	10-13
Subtransmission base	07965-4610000	1	10- 9
Bearing driver	07946-6340000	1	14-24
Clutch center holder	07923-3710000	1	8- 3, 8- 8
Bearing remover set	07936-8890100	1	15-14
P.V.T. adjust wrench	07908-4690001	1	15-16
Final retainer wrench	07910-3710000	1	16- 4, 16- 6, 16-12
Oil seal driver attachment	07946-6920100	1	16- 7, 16-10
Retainer wrench B	07910-4630100	1	16- 9, 16-11

**10 GENERAL INFORMATION**

Tool Name	Tool No.	Q'ty	Ref. Page
Dis/assembly tool A	07965-3710100	1	16- 5
Preload inspection tool	07924-3710000	1	16- 3, 16-11, 16-14
Oil seal remover	07948-4630100	1	16- 6
Final assembly/disassembly base A	07965-4630100	1	16- 3, 16- 9
Disassembly tool B	07965-4630300	1	16- 5
Gear center guide	07965-4630500	1	16- 5
Oil seal guide	07973-4630100	1	16-10
O-ring guide	07973-4630200	1	16-10
Pinion gear dis/assembly tool	07931-4630200	1	16-12

• COMMON TOOLS

Tool Name	Part No.	Q'ty	Alternate Tool	Part No.	Ref. Page
Float level gauge	07401-0010000	1			4- 8
Retainer wrench A	07710-0010100	1	Bearing retainer wrench	07910-2830000	5- 3
Retainer wrench B	07710-0010200	1	Bearing retainer wrench	07920- 3230101 3600000	14-11, 14-13
Retainer wrench body	07710-0010401	1			14-11, 14-13, 15- 3
Lock nut wrench 20 x 24 mm	07716-0020100	1			8- 3, 8- 8
Extension bar	07716-0020500	1			8- 3, 8- 8
Valve guide remover 5.5 mm	07742-0010100	1	Valve guide driver	07942-3290100	6-15
Valve guide driver B	07742-0020200	1	Valve guide driver	07942-3290200	6-15
Bearing driver outer 37 x 40 mm	07746-0010200	1	Bearing driver	07946-4300200	10-11, 15-14
Bearing driver outer 42 x 47 mm	07746-0010300	1	Bearing driver	07945-3330100	10-12, 14-13, 15- 6
Bearing driver outer 52 x 55 mm	07746-0010400	1	Bearing driver	07946- 9370100 3290000	2-11, 15- 6
Bearing driver handle outer A	07749-0010000	1	Driver handle attachment	07949-6110000	10-12, 14-13, 15- 6 16- 6, 16- 7, 16-10
Bearing driver handle outer B	07746-0020100	1	Bearing driver	07945-3230201	13-12, 13-13
Bearing driver handle outer C	07746-0030100	1			
Bearing driver inner 25 mm	07746-0030200	1	Bearing driver	07945-3710200	10-12, 12- 8
Valve spring compressor	07757-0010000	1	Valve spring compressor	07957-3290001	6-11
Drive pilot 15 mm	07746-0040300	1			14-13
Drive pilot 20 mm	07746-0040400	1			15- 6, 16- 6
Front fork oil seal Driver body	07747-0010100	1			
Attachment (E)	07747-0010600	1	Fork seal driver	07947-3710100	14-19



CABLE & HARNESS ROUTING

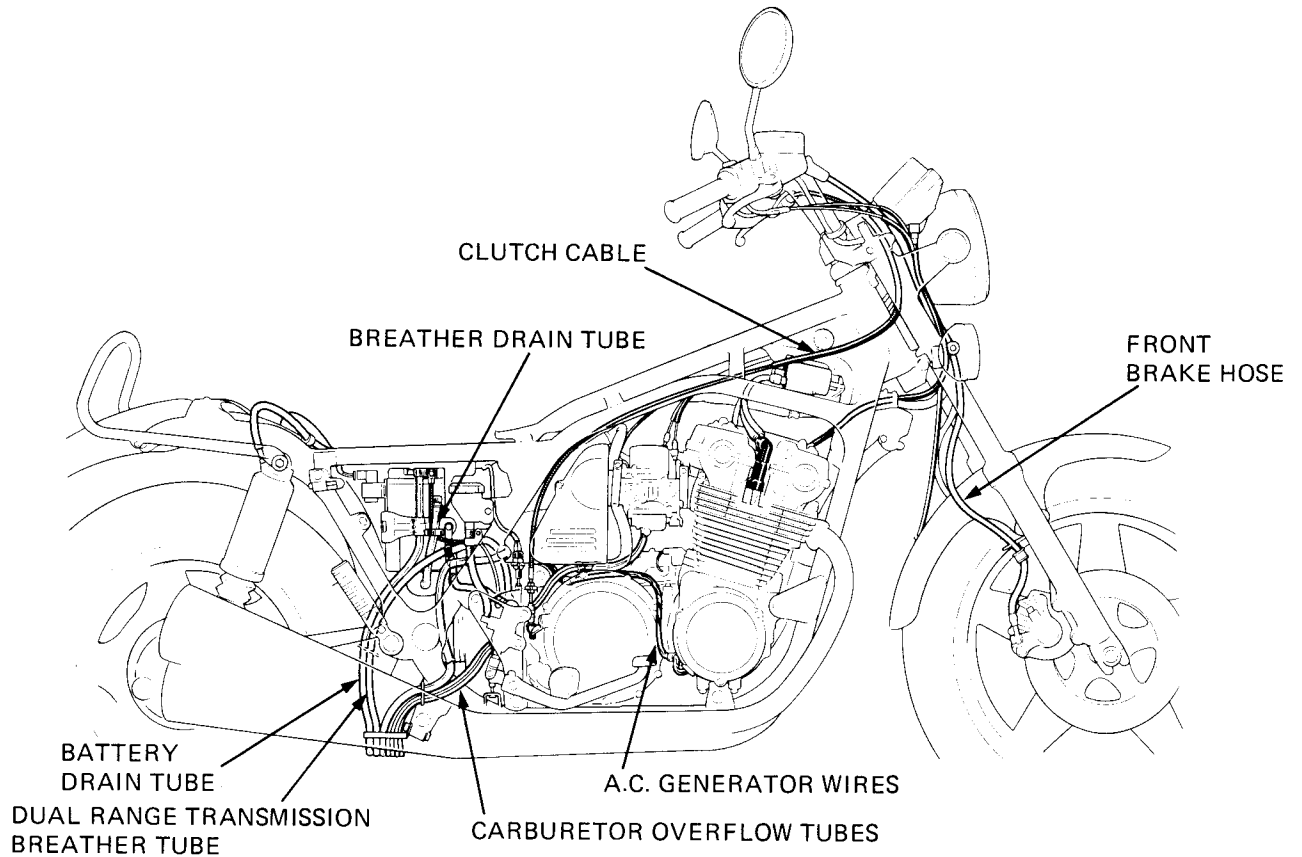
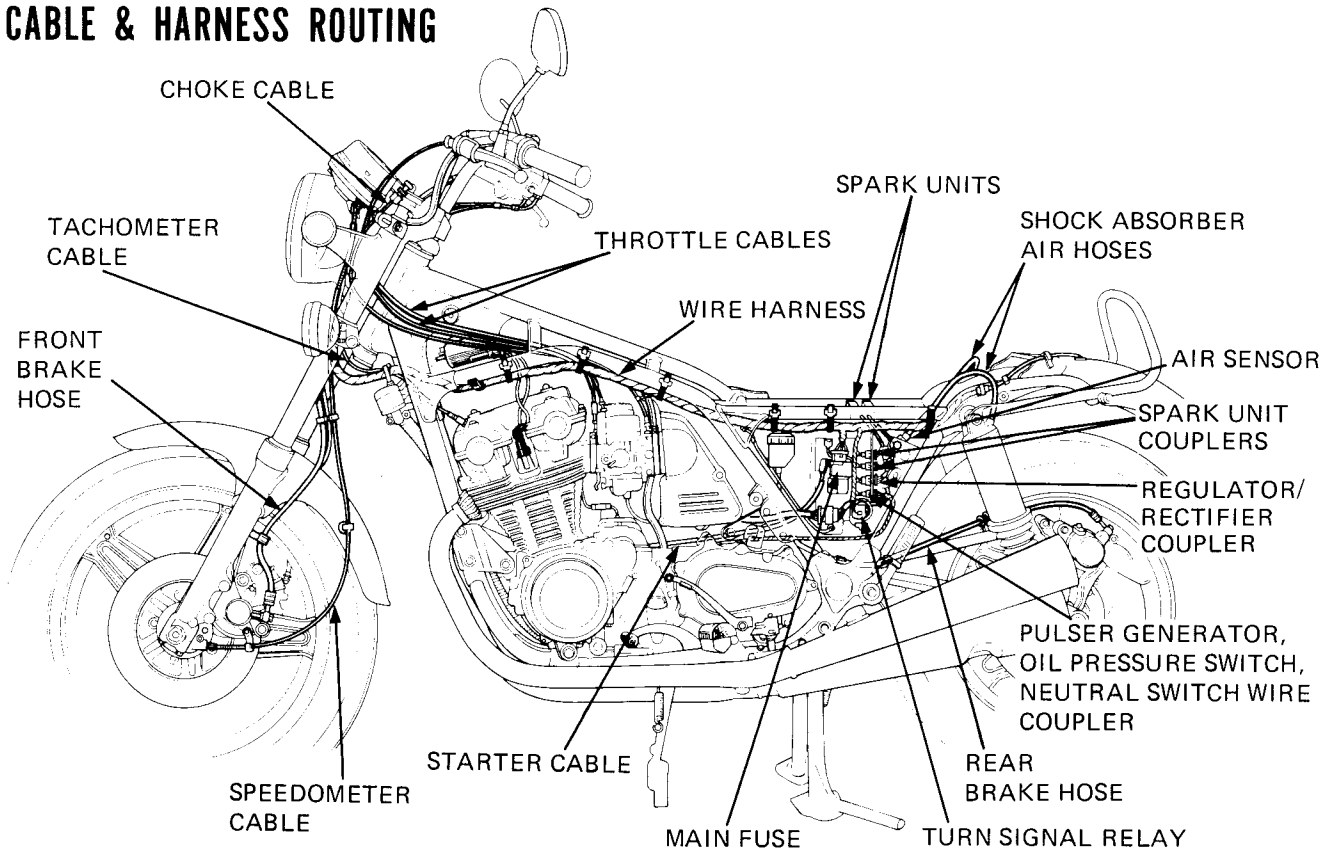

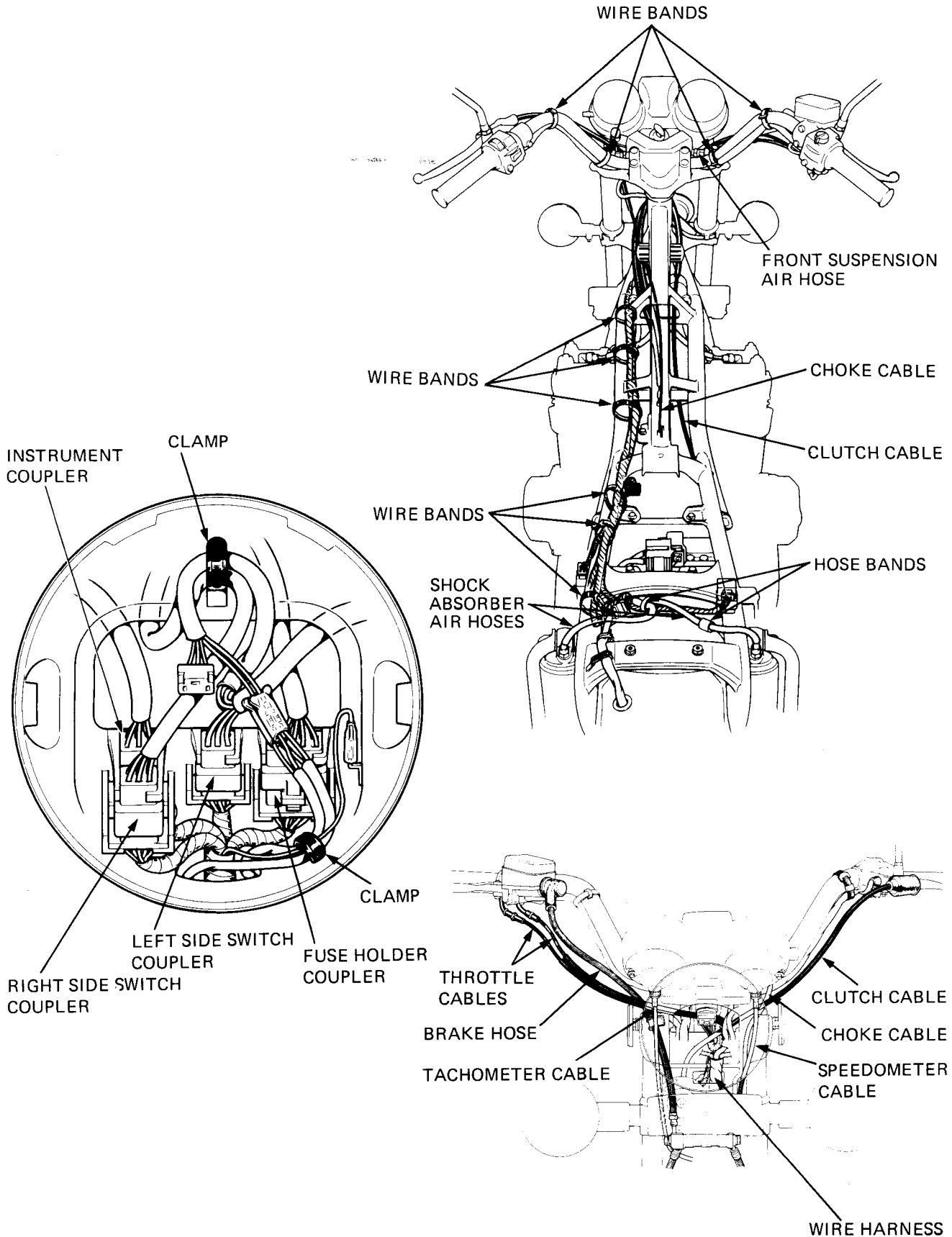



MAINTENANCE SCHEDULE

Perform the PRE-RIDE INSPECTION in the Owner's Manual at each scheduled maintenance period.

I : INSPECT AND CLEAN, ADJUST, LUBRICATE, OR REPLACE IF NECESSARY.

C: CLEAN

R: REPLACE

A: ADJUST

L: LUBRICATE

	ITEM	FREQUENCY	WHICHEVER COMES FIRST ↓	ODOMETER READING (NOTE 3)								Refer to
				EVERY	600 mi (1,000 km)	4,000 mi (6,400 km)	8,000 mi (12,800 km)	12,000 mi (19,200 km)	16,000 mi (25,600 km)	20,000 mi (32,000 km)	24,000 mi (38,400 km)	
EMISSION RELATED ITEMS	* FUEL LINES				I	I	I	I	I	I	I	Page 3- 3
	* THROTTLE OPERATION			I	I	I	I	I	I	I	I	Page 3- 3
	* CARBURETOR-CHOKE				I	I	I	I	I	I	I	Page 3- 4
	AIR CLEANER	NOTE 1		C	R	C	R	C	R	C	R	Page 3- 4
	CRANKCASE BREATHER	NOTE 2		C	C	C	C	C	C	C	C	Page 3- 5
	SPARK PLUGS			R	R	R	R	R	R	R	R	Page 3- 5
	* VALVE CLEARANCE			I	I	I	I	I	I	I	I	Page 3- 6
	ENGINE OIL	YEAR	R	R	R	R	R	R	R	R	R	Page 2- 3
	ENGINE OIL FILTER	YEAR	R	R	R	R	R	R	R	R	R	Page 2- 3
	* CAM CHAIN TENSION		A	A	A	A	A	A	A	A	A	Page 3-10
	* CARBURETOR-SYNCHRONIZE		I	I	I	I	I	I	I	I	I	Page 3-10
* CARBURETOR- IDLE SPEED		I	I	I	I	I	I	I	I	I	Page 3-11	
NON-EMISSION RELATED ITEMS	* DRIVE SHAFT JOINT					L		L		L		Page 2-12
	* FINAL DRIVE LUBRICANT					I		I		R		Page 2-9,12
	BATTERY	MONTH		I	I	I	I	I	I	I	I	Page 3-14
	BRAKE FLUID	MONTH I 2 YEARS* R		I	I	I	*R	I	I	*R		Page 3-14
	BRAKE PAD WEAR				I	I	I	I	I	I		Page 3-15
	BRAKE SYSTEM			I	I	I	I	I	I	I		Page 3-15
	* BRAKE LIGHT SWITCH			I	I	I	I	I	I	I		Page 3-16
	* HEADLIGHT AIM			I	I	I	I	I	I	I		Page 3-16
	CLUTCH			I	I	I	I	I	I	I		Page 3-17
	SIDE STAND				I	I	I	I	I	I		Page 3-18
	* SUSPENSION			I	I	I	I	I	I	I		Page 3-19
* NUTS, BOLTS, FASTENERS			I	I	I	I	I	I	I		Page 3-20	
** WHEELS			I	I	I	I	I	I	I		Page 3-20	
** STEERING HEAD BEARING			I	I			I		I		Page 3-21	

* SHOULD BE SERVICED BY AN AUTHORIZED HONDA DEALER, UNLESS THE OWNER HAS PROPER TOOLS AND SERVICE DATA AND IS MECHANICALLY QUALIFIED.

** IN THE INTEREST OF SAFETY, WE RECOMMEND THESE ITEMS BE SERVICED **ONLY** BY AN AUTHORIZED HONDA DEALER.

NOTES: 1. SERVICE MORE FREQUENTLY WHEN RIDING IN DUSTY AREAS.

2. SERVICE MORE FREQUENTLY WHEN RIDING IN RAIN OR AT FULL THROTTLE. (U.S.A. ONLY)

3. FOR HIGHER ODOMETER READINGS, REPEAT AT THE FREQUENCY INTERVAL ESTABLISHED HERE.



EMISSION CONTROL SYSTEM

The CB900C is equipped with two Emission Control Systems.

EXHAUST EMISSION CONTROL SYSTEM

The exhaust emission control system is composed of lean carburetor settings, and no adjustments should be made except idle speed adjustment with the throttle stop screw.

The exhaust emission control system is separate from the crankcase emission control system.

CRANKCASE EMISSION CONTROL SYSTEM

The engine is equipped with a closed crankcase system to prevent discharging crankcase emissions into the atmosphere. Blow-by gas is returned to the combustion chamber through the air cleaner and carburetor. Liquids are collected in the storage tank.

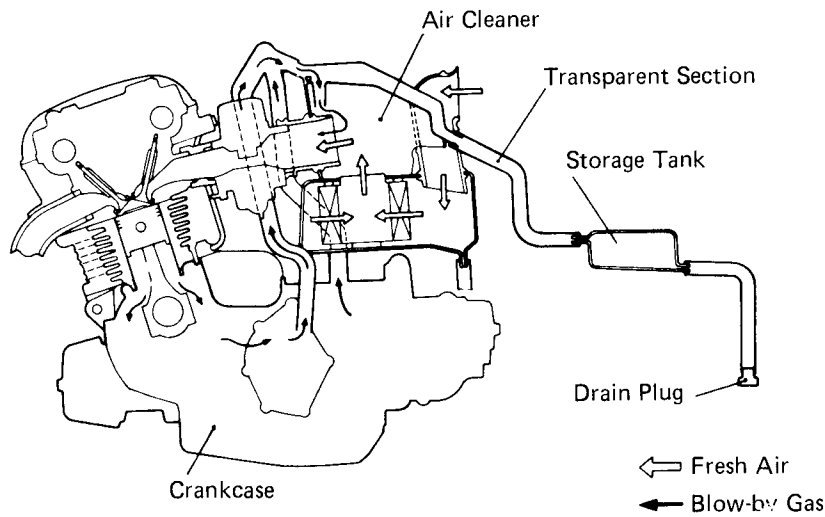

EMISSION CONTROL INFORMATION LABEL

An Emission Control information Label is located on the frame as shown. It contains basic tune-up specifications.



Vehicle Emission Control Information label.



MEMO